

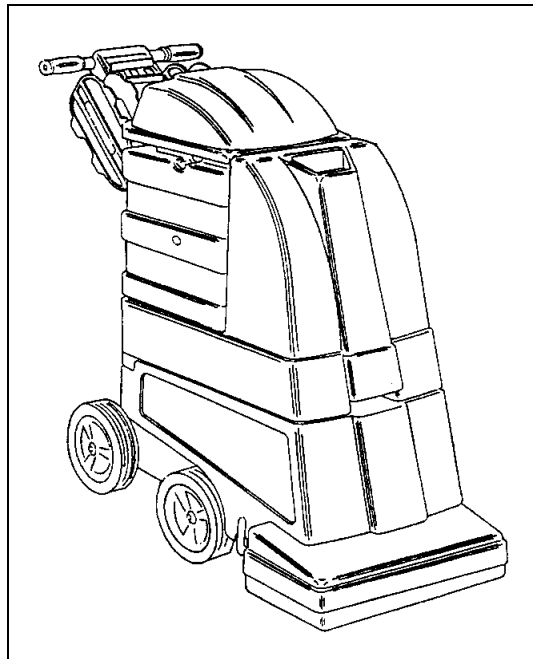

# ***Polaris & Supernova***

## **UPRIGHT CARPET & FLOOR SOIL EXTRACTOR**

### **SAFETY, OPERATION & MAINTENANCE INSTRUCTIONS**



**MODELS:**

*SP500 POLARIS 500*

*SP700 POLARIS 700*

*SP800 POLARIS 800*

*SP1200 POLARIS 1200*

*SN700 SUPERNOVA 700*

*SN800 SUPERNOVA 800*

*SN1200 SUPERNOVA 1200*

**CAUTION – READ THE INSTRUCTION MANUAL BEFORE USING THE APPLIANCE**



# MACHINE DATA

MODEL NO.	
SERIAL NO.	
DATE OF PURCHASE	
DISTRIBUTOR NAME	
DISTRIBUTOR TEL NO.	
MANUFACTURER CONTACT	Prochem Europe Ltd. Oakcroft Road, Chessington, Surrey KT9 1RH, UK Telephone: + 44 (0)20 8974 1515 Fax: + 44 (0)20 8974 1511 Email: <a href="mailto:sales@prochem.co.uk">sales@prochem.co.uk</a> Website: <a href="http://www.prochem.co.uk">www.prochem.co.uk</a>

***All information and specifications in this manual are current at the date of issue. However, because of Prochem Europe policy of continual product improvement, we reserve the right to make changes at any time without notice. Please note that this manual applies to all models and explains variations including accessories used. Therefore, you may find some explanations for variations and options not installed on your equipment.***

# CONTENTS

	PAGE NO.
WARRANTY	5
IMPORTANT SAFETY INSTRUCTIONS	6
IMPORTANT OPERATING INSTRUCTIONS	7
GENERAL OPERATING INSTRUCTIONS	8
PRACTICAL CLEANING	9
ACCESSORIES & CHEMICALS	11
GENERAL MAINTENANCE	12
GENERAL FAULT FINDING	15
SUPERNOVA FAULT FINDING & ADJUSTMENT	16
POLARIS 500 & 700 / SUPERNOVA 700 PARTS LIST	18
POLARIS / SUPERNOVA 800 & 1200 PARTS LIST	29
PUMP PARTS LIST	41
HAND TOOL PARTS LIST	42
WIRING DIAGRAMS	43
CE DECLARATION OF CONFORMITY	45



This product is marked according to the **European Directive (2002/96/EC) on Waste Electrical and Electronic Equipment (WEEE)**.

The symbol on this product indicates that this product must not be disposed of with normal household waste. Please protect human health and the environment by disposing of this product responsibly in the correct manner.

For further information regarding the disposal, treatment, recycling and recovery of this product, please contact:

Prochem Europe Sales Department  
Telephone: +44 (0)20 8974 1515

*Prochem Europe Ltd. EEE Producer Registration Number: WEE / AJ0044SY*

**European Directive (2002/95/EC) Restriction of use of certain Hazardous Substances in Electrical and Electronic Equipment (RoHS).**

This equipment does not contain more than the maximum permitted levels by weight of the following substances:

Lead (Pb), Mercury (Hg), Cadmium (Cd), Hexavalent Chromium (Cr (VI)), Polybrominated Biphenyls (PBB), Polybrominated Diphenyl Ethers (PBDE)

# WARRANTY

**DATE EFFECTIVE: 1/1/12**

As of the above date, this warranty supersedes all previous warranties and forms part of the contract of sale. Prochem Europe Ltd. (hereafter referred to as "Prochem") guarantees this machine to be free from defects in materials and workmanship for the relevant time period as shown below, and from the actual date of purchase by the user. Proof of the purchase date from a Prochem Authorised Distributor will be required for performance of this warranty.

**Rotationally moulded polyethylene tanks .....2 Years**  
**All other parts except maintenance items (see below) .....1 Year**

**THIS WARRANTY EXCLUDES NORMAL MAINTENANCE ITEMS**, including but not limited to HOSES, FILTERS, O-RINGS, DIAPHRAGMS, VALVES, DRIVE BELTS, GASKETS, CARBON BRUSHES and damage to motors and other components as a result of failure to replace normal maintenance items. THIS LIST IS NOT EXHAUSTIVE.

**To obtain performance of this warranty, contact the Prochem Authorised Distributor who supplied the product.**

**The Prochem Authorised Distributor is responsible as the selling agent for the provision of initial training in the correct use and application of the machine and approved chemicals. The distributor is also responsible for service maintenance and repairs during and after the warranty period and the administration of any warranty claims in conjunction with the Prochem Service Department. Failure of any of these provisions and responsibilities may invalidate the warranty and the authorised status of the distributor.**

If Prochem receives notice of any defects during the warranty period, Prochem reserves the right to either repair, or replace components that prove to be defective. Goods must be returned before the warranty is approved. Goods sent out prior to the return of faulty items will be invoiced at current prices, subject to standard payment terms (see Prochem Standard Terms and Conditions of Sale). Replacement parts supplied under warranty will be guaranteed for the remainder of the original machine warranty and **NOT** from the date of installation. Spare parts supplied after the expiry of machine warranty may be covered by a manufacturer's warranty, subject to inspection by Prochem Europe Ltd. and at its sole discretion. Normal maintenance items, however, are not covered. Replacement or credit of any returned parts will be at the discretion of the Prochem Service Department. Any subsequent refusal to accept their decision will serve to invalidate this warranty with immediate effect.

**PROCHEM AUTHORISED DISTRIBUTORS** are responsible for machine and accessories service back up during and after the warranty period. Prochem will furnish parts if the warranty is approved, but **DISTRIBUTORS** will be responsible for fitting, service, labour and related charges including travel, if applicable, and the cost of returning the machine or parts to Prochem. If any chargeable work is undertaken by Prochem for **DISTRIBUTORS** the labour, parts (if applicable) and return carriage will be charged at **FULL LIST PRICE**. If warranty is approved due to genuine manufacturing defect, then labour charges and return carriage charges may be waived at Prochem's discretion.

Prochem may send replacement parts to customers supplied by a **DISTRIBUTOR** or directly by Prochem, subject to the same conditions of replacement and payment above. The customer, however, will be responsible for fitting, labour and the carriage costs of returning repaired parts. Alternatively, Prochem will undertake warranty work at Chessington, subject to the same conditions, but the customer will be responsible for all carriage charges.

*Any of the following circumstances involving the machine will serve to invalidate this warranty:-*

**NORMAL WEAR, ACCIDENTS, USE OF THE MACHINE FOR A PURPOSE OTHER THAN THAT FOR WHICH IT WAS INTENDED, INCORRECT MAINTENANCE, THE USE OF CHEMICALS OTHER THAN THOSE SUPPLIED OR APPROVED BY PROCHEM, INCORRECT INSUFFICIENT OR NON-USE OF DEFOAMER, EXPOSURE TO EXTREME TEMPERATURES OR CONDITIONS, INCORRECT INSTALLATION OR REPAIR & UNAUTHORISED INTERVENTION.**

Liability is excluded for the following:-

All forms of damage and special damage founded in tort (apart from death and personal injury) and contract law including but not limited to consequential loss, loss of income and losses incurred in reliance of the contract; service, labour or third party charges and the cost of returning the machine or defective parts to Prochem or Prochem's Authorised Distributor.

As against a person dealing as a consumer, this warranty creates specific rights in addition to any statutory rights, which are unaffected. As against a person dealing otherwise than as a consumer, however, this warranty excludes any implied term that the machine will correspond with a description or a product sample.

With the exception of some specific products which are labelled and intended to be used by a consumer, all equipment, machinery, accessories, products, services and advice supplied by Prochem is intended for professional and industrial use only.

Your Prochem unit is designed to give you many years of reliable service. If a problem should arise during or after the warranty period, contact the Prochem Authorised Distributor or the Prochem Service Department, for details of the services available. Only the original purchaser of the new equipment may seek performance of this warranty – these rights cannot be transferred to a third party.

*Prochem Europe Ltd.*

*Oakcroft Road, Chessington, Surrey KT9 1RH, ENGLAND*

*Telephone: + 44 (0)20 8974 1515 Fax: + 44 (0)20 8974 1511*

*Machine Warranty Issue 8 1/1/12*

# IMPORTANT SAFETY INSTRUCTIONS

**PLEASE READ THE FOLLOWING IMPORTANT SAFETY INSTRUCTIONS (!!)  
BEFORE ATTEMPTING TO USE THIS MACHINE. FAILURE TO OBSERVE THE  
INSTRUCTIONS MAY RESULT IN PERSONAL INJURY.**

## **!! CAUTION**

*Read the instruction manual before using the appliance.*

## **!! SOUND PRESSURE LEVEL**

*The sound pressure of this machine, when in use, does not exceed 85 dB (A).*

## **!! APPLIANCE SUITABILITY**

*This appliance is suitable for commercial use, for example, in hotels, schools, hospitals, factories, shops, offices and rental businesses.*

*This appliance is not intended for use by persons (including children) with reduced physical, sensory or mental capabilities, or lack of experience or knowledge, unless they have been given supervision or instruction concerning use of the appliance by a person responsible for their safety.  
**!! CHILDREN** should be supervised to ensure they do not play with the appliance.*

**!! FOR MAINS POWERED APPLIANCES** during cleaning and maintenance – the plug is to be removed from the outlet socket.

## **!! TRAINING**

*You must be trained in the operation of this machine before use. Please read this manual carefully and obtain operating instruction from your Prochem Distributor or authorised representative in the correct use of this equipment and suitable chemicals before attempting to clean.*

## **!! REPAIRS**

*Should any repairs, including supply cord replacement be required, we recommend that the appliance be returned to an authorised dealer.*

## **!! ELECTRICAL CABLE INSPECTION & REPLACEMENT**

*This machine must be earthed while in use to protect the operator from electric shock. It is equipped with a sealed and approved EC three conductor cable and three-prong 13A plug. If the supply cord is damaged it must be replaced by a special cord or assembly available from the manufacturer or its service agent. During operation a hazard may occur when running the machine over the power supply cord. The power supply cord should be regularly inspected for signs of damage. If the power supply cord is damaged, it must be replaced.*

## **!! EXTENSION CABLES**

*Avoid using extension cables with this machine. If an extension cable is used it should be of a suitable rating and no longer than 30 metres. Use only three wire CE approved extension cable with CE approved three-prong earthed plugs and three pole receptacles that accept the machine 13 amp plug.*

**!! DO NOT** allow the rotating brushes to come into contact with the supply cord.

**!! DO NOT** pull the machine by the power cable or hoses and do not handle the plug or appliance with wet hands.

## **!! RCD CIRCUIT BREAKER**

*In common with other household and commercial electrical equipment, an 'RCD' circuit breaker plug device is strongly recommended for this type of equipment.*

**!! DO NOT** use a multiple adaptor socket to connect the machine and heating units or other devices to a single extension cable.

**!! DO NOT** stand the machine in water to operate such as during flood extraction.

**SERIOUS INJURY OR DEATH MAY RESULT IF MACHINE IS IMMersed IN WATER!**

**!! DO NOT** use this machine with or near flammable vapours. These machines can ignite flammable vapours such as fuels, solvents or thinners.

**!! DO NOT** operate the machine unless it is completely assembled.

**!! DO NOT** attempt repairs or maintenance unless you are suitably qualified or experienced. Repairs and maintenance should only be performed by qualified personnel and the machine should be tested for electrical safety before re-use.

**!! SPRAY LIQUID** ejection could be hazardous as a result of its temperature, pressure or chemical content.

**!! IF FOAM** or liquid escapes from the appliance, switch off immediately.

**!! ALWAYS** disconnect machine from mains supply when left unattended, when emptying the waste container or cleaning the appliance.

**!! WHEN CLEANING THE WASTE BUCKET** use a broad spectrum disinfectant cleaning agent to prevent contamination from any infectious material.

## **!! MOVING PARTS**

*Keep hair, loose clothing, fingers and all body parts away from openings and moving parts.*

## **!! CLEANING STAIRS**

*Use extra care when using this machine in conjunction with extension hoses to clean stairs. Ensure the machine is in a firm and stable position at the foot of the stairs. Do not position machine at top of stairs.*

# IMPORTANT OPERATING INSTRUCTIONS

**PLEASE READ THE FOLLOWING IMPORTANT OPERATING INSTRUCTIONS (!) BEFORE ATTEMPTING TO USE THIS MACHINE. FAILURE TO OBSERVE THE INSTRUCTIONS MAY RESULT IN DAMAGE TO THE EQUIPMENT.**

**! DO NOT** expose the machine to rain or freezing temperatures. Drain solution system and store indoors when not in use.

**! DO NOT** operate the machine without solution and waste tank filters.

**! DO NOT** use boiling water or temperature in excess of 71<sup>0</sup>C.

**! DO NOT** use chemicals in the machine other than those manufactured or recommended by Prochem Europe.

**! DO NOT** use the machine for dry vacuuming. The vacuum must only be used for wet extraction in conjunction with the spray system.

**! DO NOT** run the solution pump dry. Always switch off and disconnect the machine when re-filling with solution.

**! ALWAYS** use a clean bucket to fill the solution tank.

**! AFTER USE** flush solution system and rinse the waste tank with clean water and remove loose fibres from the vacuum filter.

**! ALWAYS** observe directions and safety precautions on chemical products.

**! ALWAYS** pre-test carpet, fabric or flooring surface for colour fastness and suitability with ready-to-use cleaning solution before proceeding.

**! ALWAYS** use defoamer in the waste tank to control foaming from previous shampoo residues in the carpet.

**! USE ONLY** genuine replacement parts for this machine, supplied by an authorised Prochem Distributor.

**! DO NOT** use this machine for any purpose other than for its intended design function. Any deviation from its proper use or purpose and any consequential damage that may occur is the sole responsibility of the user.

**! ALWAYS** discharge soiled solution to a sewage drain linked to a sewage treatment facility.

**! DO NOT** discharge soiled solution into roadside storm drains.

**! DO NOT** put any object into openings. Do not use with any opening blocked; keep free of dust, lint, hair and anything that may reduce airflow.

**! DO NOT** pick up anything that is burning or smoking, such as cigarettes, matches or hot ashes.

# GENERAL OPERATING INSTRUCTIONS

## BEFORE OPERATING THE MACHINE

Read the manual carefully and completely before attempting to operate the unit. This manual has important information for the use and safe operation of the machine and should be kept available at all times. This machine will ensure years of satisfactory service if operated and maintained according to recommendations in this manual. If additional help or information is needed, please contact your distributor or Prochem.

Prochem carpet soil extraction machines have been designed with the operator in mind. Provided you read the instructions relating to the care of your machine and follow them carefully and take advantage of the helpful hints and advice that we have passed on, you will achieve excellent cleaning results and very quickly pay for your investment. A detailed operational guide is given in the following sections, however, the following important points must be emphasised.

## FAILURE TO OBSERVE THESE INSTRUCTIONS MAY SERIOUSLY AFFECT THE PERFORMANCE OF THE MACHINE AND INVALIDATE THE WARRANTY

- Connection instructions - The 220 - 240V AC models have been fitted with the appropriate EC type sealed power cable and 3 prong 13 amp plug for the UK market. Ensure the machine is connected to a 13 amp socket outlet having the same configuration as the plug. No adapter should be used with this machine. Any modification to the plug type may be dangerous and will void the warranty.
- This equipment is intended for commercial use only.
- This machine is designed for use on carpet and upholstery extraction applications and hard floor surfaces (Supernova model only) as per instructions and recommendations written in this manual. Any deviation from its proper use or purpose and the consequential damage that may occur is the sole responsibility of the end user.
- Disconnect the power cord from outlet before servicing. Do not leave machine connected to an electrical outlet when unattended.
- Do not immerse or use this machine in standing water. Such use may cause electric shock.
- This equipment is not designed to handle or use combustible/volatile substances such as gasoline or kerosene, in, on, or near the machine. The use of such materials will cause an extreme hazardous condition.
- Use defoamer at all times to prevent damage to the vacuum motor(s).
- Do not use water in excess of 160°F (71°C).
- To prevent seal damage and chemical build-up to the pump system, run clean water through the solution lines after each use.
- All repairs must be carried out by an authorised Prochem distributor.
- Repairs should only be carried out by a qualified person.
- Do not use replacement parts other than genuine manufacturers parts as specified in the parts list.
- Do not use chemicals in the machine other than those supplied or approved by Prochem Europe.
- Do not use the machine as a 'dry' vacuum. Always pre-vacuum carpets and floors thoroughly with a separate 'dry' vacuum cleaner.
- Keep the solution tank and filter clean. Always use a clean bucket to fill the solution tank or fill direct from water supply.
- Clean the waste bucket and vacuum filter daily. Do not attempt to re-fill the solution tank before emptying the waste bucket.
- After use, flush through the pump, solution lines and waste tank with at least two litres of hot water (Do not use water in excess of 71°C).
- Do not allow the machine, hoses or tools to freeze. Freezing may seriously damage the pump and fittings. Always drain solution and store indoors when not in use. When in transit during freezing weather, insulate and cover machine, wand and hoses.

# PRACTICAL CLEANING

## CLEANING TIPS & PREPARATION

### CHECKING THE FITTING AND CONDITION

Check the condition of the area to be cleaned. Look for loose carpet, heavily soiled areas, stains or spots and worn areas. Bring these to the attention of the person in charge before proceeding. Make sure all edges of the carpet are secured or tacked in place and all seams are sewn or glued tight. This is your protection against shrinkage.

### IDENTIFY CARPET AND FIBRE TYPE

Synthetic fibres such as nylon and polypropylene respond well to hot water extraction cleaning and are more resistant to alkaline chemicals and shrinkage than wool or wool-mix fibres. When cleaning wool or wool-mix fibres, always use approved cleaning solutions and avoid over-wetting.

### TESTING FOR COLOUR FASTNESS

Locate an inconspicuous spot on the area to be cleaned. Test carpet for colour-fastness before proceeding. Apply S709 Multi Pro diluted at 1 part to 4 parts water and cover with a clean white towel or tissue and place a weighted object on top. Wait approximately 10 minutes then remove weight and examine towel or tissue. If there is no colour transfer the carpet should be safe to clean. If there is a colour change on the carpet or transfer of colour to the towel or tissue then carry out the same test with B109 Fibre & Fabric Rinse diluted at 1 part to 20 parts water. It may be possible to clean the carpet using B109 Fibre & Fabric Rinse. For further advice contact Prochem's technical department.

### MOVING AND REPLACING FURNITURE

Remove the furniture from the area to be cleaned. Large pieces can be moved to the opposite end of the room from where you start cleaning and replaced when cleaning is completed. Plan your cleaning route. Start cleaning at the furthest point away from where you plugged in the machine and work back towards the outlet so that the power cable will not get in the way. After cleaning carpet, always place foil protector pads under furniture legs to prevent moisture from damaging the finish and dye and rust from transferring to the carpet.

### DRY VACUUMING & PRE-TREATMENT

Vacuum clean the area using an upright vacuum. **DO NOT USE THE MACHINE AS A DRY VACUUM!** Heavily soiled areas or areas of concentrated foot traffic should be pre-treated with recommended pre-spotting or pre-spray solutions.

## CLEANING CARPET

### 1. PREPARE THE MACHINE

Make sure switch is in the "off" position and all hoses are connected. Using only approved cleaning solution, mix according to label instructions and add to the solution tank. Make sure the drain hose is clipped in the upright position. To reduce foaming in the waste bucket(s), add Defoamer solution to the removable waste bucket(s) according to label instructions. For excessive foam problems introduce Defoamer through the vacuum nozzle with vacuum switched on. Do not add Defoamer solution to solution tank. Place waste bucket(s) onto machine and close lid.

### 2. TO CLEAN

Turn on the vacuum, pump and brush switches. Lift on the handle grips to ensure that the front of the machine rests on the carpet or floor surface. Slowly pull the machine backward while pressing on the carpet spray switch (below the left handle grip). On Supernova models, the ACTIVATE switch operates the solution release and brush. Use the direction lever to operate the machine in the direction you want to clean. Monitor the extraction process through the vacuum lid. Release the spray switch 6" before ending the cleaning stroke.

NOTE: If dirty solution does not appear through the vacuum lid, check the lid is resting properly on the recovery bucket(s) and that the front of the machine is in full contact with the carpet during cleaning mode.

Roll machine forward on its four wheels for next stroke. Make overlapping passes to prevent streaking. Check solution level from time to time (see solution indicator tube on rear left corner of the back). Repeat cleaning stroke with 3" overlaps.

NOTE: If foam appears on vacuum lid, **TURN THE VACUUM SWITCH OFF IMMEDIATELY** and add more defoamer to the waste bucket(s). When the solution tank is empty, turn off the vacuum pump and brush switches and empty the waste bucket(s) into waste sink or toilet then rinse and repeat steps 1 and 2.

### 3. CLEAN UP

Clean lid filter screen and rinse out waste bucket(s). Wipe all surfaces including bottom of machine. Remove carpet lint and strings from brush and vacuum nozzle.

To empty solution tank, unclip the drain hose and empty into waste bucket.

Coil power cable onto cable wrap.

Clean solution line filter.

Lean machine back on its four wheels during storage or when not in use to prevent brush distortion.

Always empty machine before storage to prevent compression to wheels.

## CLEANING UPHOLSTERY & STAIRS

**CAUTION – WE STRONGLY RECOMMEND ATTENDING AN UPHOLSTERY CLEANING COURSE BEFORE ATTEMPTING TO CLEAN FABRIC UPHOLSTERY.**

### General instructions

Cleaning upholstery with success requires a good knowledge of the type of fabric to be worked on. Look for the cleaning instruction label sewn on the underside of the furniture for the recommended method of cleaning the fabric. If it calls for dry cleaning, do not attempt to clean with the wet extraction method. Otherwise, damage to the fabric could occur. Extraction works well on most wet-cleanable fabrics, including synthetic (acrylic) velvets.

Before proceeding, test the fabric for colour-fastness. Apply a small amount of ready-to-use cleaning solution on the fabric in an inconspicuous area. Wait for 2 to 3 minutes and blot the area with a white terry cloth towel. If no colour comes off onto the towel, the fabric should be safe to clean. If a little colour comes off, there is some risk of colours running when you clean. It may be possible to stabilise colours by cleaning with B109 Fibre & Fabric Rinse. Refer to the "Testing For Colour-Fastness" under Cleaning Tips and Preparation. On heavily soiled areas like arm rests, pre-treat with a recommended pre-spray.

### 1. TO ATTACH ACCESSORY HOSE

Use the following procedure to connect an upholstery tool or stair tool accessory hose to the Polaris machine.

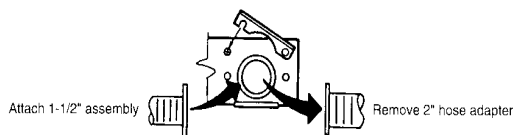

Remove 2" hose adaptor connection from machine. Attach AC1041 Accessory Hose 1 1/2" assembly with adaptor plate to vacuum lid inlet. Pull back female quick connect sleeve on the machine and insert male plug on the accessory solution hose. Attach upholstery tool or stair tool to the accessory hose.

2. Complete step 1 under Carpet Cleaning Instructions using approved upholstery cleaning solution for fabric upholstery or carpet cleaning solution for stairs.

### 3. TO CLEAN UPHOLSTERY & STAIRS

Turn pump and vacuum switch on. Depress upholstery stair tool trigger while pulling tool across upholstery or stair carpet surface. Clean with the upholstery tool using as little solution as possible. Make overlapping passes to prevent streaking. Go over the area you just cleaned without depressing the solution trigger (vacuum only) and gauge the amount of moisture extracted for dryness. On heavily soiled areas like arm rests and stair treads, pre-treat with a recommended pre-spray. NOTE: If foam appears on vacuum lid, TURN THE VACUUM SWITCH OFF IMMEDIATELY and add more defoamer to the waste bucket(s). Continue cleaning until cleaning solution is used. Empty waste bucket(s) into waste sink or toilet then rinse and repeat steps 2 and 3.

### 4. CLEAN UP

Clean lid filter screen and rinse out waste bucket(s). Wipe all surfaces including bottom of machine. Remove carpet lint and strings from brush and vacuum nozzle.

To empty solution tank, unclip the drain hose and empty into waste bucket.

Coil power cable onto cable wrap.

Clean solution line filter.

Lean machine back on its four wheels during storage or when not in use to prevent brush distortion.

Always empty machine before storage to prevent compression to wheels.

# ACCESSORIES & CHEMICALS

## ACCESSORIES

### VACUUM & SOLUTION ACCESSORY HOSE

A 5 metre hose assembly for use with upholstery tool or stair tool.

### STAINLESS STEEL UPHOLSTERY TOOL

A lightweight stainless steel cleaning tool that, with care, will not give the problems of the softer alloy materials or plastics, the rough edges of which could damage fine fabric. Suitable for use on all wet-cleanable fine fabrics with an ultra-fine spray tip to avoid over-wetting. This tool is essential for upholstery cleaning.

### CARPET & STAIR HAND TOOL

A larger and heavier hand tool designed for extraction cleaning stair carpeting, edges, small rugs and inaccessible areas. Also ideal for rinse extracting stains after treatment with an appropriate Prochem spotting agent. *These tools are NOT recommended for upholstery cleaning.*

## CHEMICALS

**Prochem** specialise in manufacturing chemical products for the soft furnishing cleaning industry, including carpets, floor coverings, upholstery fabrics and curtains. This section refers only to the basic

**Prochem** chemicals for general on-site carpet cleaning using the hot water extraction method.

### S775 EXTRACTION PRO

A wide use carpet cleaning formula containing a high concentration of non-resoiling detergents, builders and brighteners for effective cleaning of synthetic and natural fibre carpets. S775 has an approximate pH of 8.5 and should be diluted with hot water at the rate of 10 ml. per litre (1 to 100).

### S709 MULTI PRO

A concentrated pre-spotter and traffic lane cleaner for treating spots, stains and heavily soiled traffic areas prior to extraction cleaning. Dilute with warm water at 1 - 4 to 1 - 8 and apply by sprayer. For best results, brush into pile using **Prochem** carpet pile brush before following up with extraction cleaning process. S709 has a diluted pH of 10.5, therefore always pre-test fibres for colour fastness before use.

### B109 FIBRE & FABRIC RINSE

A mild acidic concentrate for use as a cleaning/stabilising rinse to restore correct pH to the fibre. B109 will help to stabilise fugitive dyes and reduce the possibility of 'jute browning' caused by over-wetting or the use of alkaline cleaning solutions. B109 can be used in place of S775 in the extraction machine solution tank, or applied by sprayer after cleaning. Dilute 10 ml. per litre of warm water through your machine. B109 is normally only used when a dye test suggests the possibility of dye bleed or on light coloured carpets when JUTE is part of the construction and may cause BROWNING.

### S760 LIQUID DEFOAMER

Always use S760 especially when foam problems from soapy residue left from previous shampoo cleaning are encountered. Mix 20 ml. of S760 with 500ml of cold water and add to vacuum hose and recovery tank. As you drain off to empty the recovered soiled solution, you simply add more S760 as necessary. Remember, it is only necessary to add S760 when extraction cleaning previously shampooed carpets, so always check the recovery tank for foam at the start of each job.

### STAIN REMOVERS, SPOTTERS, PROTECTORS & DEODORISERS

Speciality products such as those listed above are available from the **Prochem** range. Refer to the chemical section of the Product Catalogue for more details. Individual Product Safety Data Sheets on all products are available direct from **Prochem** or Authorised **Prochem** Distributors.

### FLOOR CLEANING (SUPERNOVA MODELS)

A variety of chemical products may be used in conjunction with the Supernova machines for hard floor cleaning. For general cleaning use A250 ALKLEEN at 1 part to 50 parts water in the machine solution tank. For stone tile floors use A257 QMT STONECLEAN at 1 part to 50 parts water. For cleaning and sanitizing hard floors, use D500 MICROSAN CONCENTRATE at 1 to 50 parts water. Hard surface chemicals used in the machine solution tank should be low or moderate foaming and non-corrosive.

# GENERAL MAINTENANCE

The Polaris and Supernova machines are engineered and built to require a minimum of maintenance. But like any machine, it does require some care to keep it in optimum working condition. Careful attention to these maintenance instructions will give you maximum operating performance and will increase the life expectancy of the machine. To ensure a trouble-free machine, we strongly advise the following preventative maintenance.

## DAILY MAINTENANCE

The following should be carried out at the end of each cleaning session.

### POWER CABLE & PLUG

Check the condition of the power cable and plug. Make sure all wires are correctly located and tightly connected. If damaged, the power cable and plug assembly must be replaced.

### DO NOT ATTEMPT REPAIR.

**Instruction for replacement of power cable with combined plug (all machines)**

**!! CAUTION - ONLY QUALIFIED MAINTENANCE PERSONNEL SHOULD ATTEMPT THE FOLLOWING REPAIR**

Should the power cable require replacement, please follow the instructions below.

1. The replacement cable and plug shall be of the same specification as the original Prochem part number BE4901 (3 core 1.5mm with 13Amp sealed plug unit)
2. Ensure that machine is disconnected from electrical supply and open electrical housing by means of tool required.
3. Disconnect the live (brown), neutral (blue) and earth (green/yellow) wires from the cable terminal block by means of unscrewing the terminal block wire clamp screws.
4. Release the outer cable clamp next to the terminal block by unscrewing the two securing screws, then unscrew the outer cable gland to release the cable which can then be pulled out of the cable gland assembly.
5. Insert the new cable through the gland, then secure and clamp the outer cable by means of tightening the outer cable gland and the two securing screws next to the terminal block.
6. Connect the live (brown), neutral (blue) and earth (green/yellow) wires to the cable entry gland terminal block by means of inserting the wire conductors into the terminal block as follows :-

The conductor of the wire coloured brown shall be connected to the terminal marked (L), the conductor of the wire coloured blue shall be connected to the terminal marked (N) and the conductor of the wire coloured green and yellow shall be connected to the terminal marked with the Earth symbol thus - 

7. Ensure that all connections are secure and close machine electrical housing and secure with tool required.

### SOLUTION TANK

Rinse the solution tank and pump through with a solution of B109 Fibre & Fabric Rinse and warm water. Check the solution tank filter and clean if necessary. Unscrew bowl and rinse filter screen as required.

### RECOVERY BUCKET(S) & LID

Rinse with clean water and broad spectrum disinfectant solution. Clean the vacuum filter attached to the lid. Remove soil and lint build-up on the outside and inside of the filter screen attached to the lid. Lint should be cleaned off so that airflow is not impeded. Check the lid seal (dome gasket) and repair or replace to ensure a good seal on the top of the bucket.

### CLEANING HEAD, HAND TOOLS AND HOSES

Inspect the wand shoe, rotating brush, bottom cover and hand tool for sharp edges or damage. Check the **spray jets** for debris, correct alignment and spray pattern. Clean if necessary using **only** a soft bristle brush - **DO NOT use metal or wire**. Rinse the upholstery tool vacuum hose with hot water to prevent soil build-up.

### Check all nuts and bolts and tighten if necessary.

Pay particular attention to the base cover and vacuum shoe securing screws.

**Always keep the machine clean inside and out.**

## WARNING! FREEZING PROTECTION

If your machine is exposed to freezing weather with solution in the components, the solution will **FREEZE** and in most cases **SERIOUSLY DAMAGE** the machine. To avoid damage, consider the following in the winter season. When the machine is not in use, store it in a **heated building** and pump out all the cleaning solution from the machine and hand tool.

## WEEKLY MAINTENANCE

At least once a week, inspect the internal components, solution fittings and electrical connections. Check for signs of **fluid leakage** and tighten or replace fittings as necessary. Make sure all **electrical connections** and **cables** are in place.

### **Solution Lines and Fittings**

Flush the machine with a solution of 1 part water with 20 parts B109 Fibre & Fabric Rinse in order to neutralise the alkaline residue left by the cleaning solution.

### **Quick connect coupler (Solution hose connection)**

Spray with WD-40 or equivalent lubricant to prevent coupler from sticking.

## HOW TO RELEASE THE MOTOR HOUSING

**!! CAUTION - ONLY QUALIFIED MAINTENANCE PERSONNEL SHOULD UNDERTAKE THE FOLLOWING PROCEDURE**

1. Make sure that the power cable is unplugged from the power socket.
2. Drain the solution tank.
3. Set the handle to the low position and lock it in place.
4. Carefully raise the dome and remove the recovery bucket(s).
5. Return the handle to the upright position and lock it in place.
6. Tilt the machine backwards and downwards until the cord wrap meets the working surface.
7. The underside of the machine should now be vertical with the brush uppermost.
8. Locate the screw (Philips head) or 7/16 AF hex bolt at the top of each long frame tube almost where the tube meets the brush housing.
9. Carefully undo and withdraw the two screws/bolts making sure to support the brush housing when the second screw is loosened (the whole of the lower part of the machine pivots on the rear axle and may drop down suddenly if unsupported).
10. Lower the brush housing to the working surface to gain access to all internal items.
11. On 800 and 1200 models remove the two self-tapping screws on each side of the blue brush chamber cover to access the components at the front of the machine.

## SOLUTION PUMP

**!! CAUTION - ONLY QUALIFIED MAINTENANCE PERSONNEL SHOULD ATTEMPT THE FOLLOWING REPAIRS**

A diaphragm type pump is fitted to the Polaris machine and requires little maintenance other than occasional inspection of the pump head to check for any fluid leakage. The following components should be inspected and cleaned, or replaced as necessary. See parts illustration in this manual for further reference.

- **CHECK VALVE ASSEMBLY**
- **DIAPHRAGM**
- **CAM DRIVE BEARING**
- **MOTOR**

In the event of a reduction in operating pressure, leakage or pump failure, refer to the '**Fault Finding Guide**' and contact your **Prochem** Distributor.

## VACUUM MOTOR

**!! CAUTION - ONLY QUALIFIED MAINTENANCE PERSONNEL SHOULD ATTEMPT THE FOLLOWING REPAIRS**

The vacuum motor is lubricated for life - no additional lubrication is required. The only other maintenance that may be required is changing the motor brushes. **This should only be carried out by an individual with THOROUGH knowledge of electric motors.**

**The brushes should be changed before the brush wears to within 3/8" of the brass holder.**

**With heavy usage we recommend that the brushes be checked every 3 months. The recommended inspection period for normal usage is at least every 6 months. The estimated brush life is approximately 400 to 450 hours, but inspection and replacement should take place at least every 350 hours to prevent the possibility that brush wear may cause damage to the vacuum motor.**

On re-assembly, the lead wires must be kept away from the rotating parts and the motor frame. Always ensure that the green earth wire is re-connected to the vacuum motor body to ensure safe operation. To achieve maximum life, the brushes should be seated on the commutator before full voltage is applied. Do this by applying 50% of the rated voltage for thirty minutes. In the event of electrical or mechanical failure, refer to the General Fault Finding Guide page in this manual and contact your Prochem Distributor. Although some service parts are available, we recommend that defective vacuums be replaced.

## BRUSH DRIVE BELT SERVICE / REPLACEMENT

1. Remove (2) ¼-20 hex screws attaching lower frame to upper frame. On models 800 and 1200, remove (4) 8-32 screws on the sides of the brush chamber cover.
2. Remove (2) spring cover plate assemblies and carefully remove springs from the slide blocks.
3. Loosen (2) ¼-20 hex screws that hold brush motor bracket in place. Push bracket toward front of machine to loosen belt.
4. Remove right open-end and left pulley-end cover plates.
5. Slide brush assembly and slide blocks out from their guides. Replace worn and defective belt.
6. Re-install above components. Clean accumulated lint or debris inside the slide block guides and check for wear on the Teflon® surfaces. Replace if necessary.

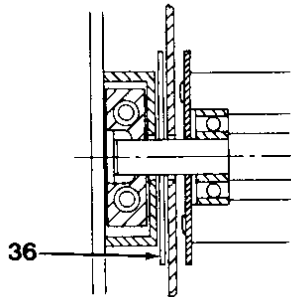

The slide block washer (Item 36) must be installed between the slide block guide and inside the divider wall. Adjust belt tension by moving motor bracket toward the rear. Apply minimum belt tension when the hex bolts are tightened to allow for a smooth vertical brush movement. If the belt is too loose it will skip when brush is applied on the carpet. If the belt is too tight it won't allow for correct up and down movement.

## BRUSH ASSEMBLY / BEARINGS SERVICE / REPLACEMENT

1. Repeat steps 1 to 4 above
2. Remove slide blocks from the ends of the brush shaft.
3. Remove (4) screws from the string guard. Tap the shaft toward the right open end to remove the bearing.
4. Remove (4) screws from slinger and pull off brush core. Scrape off old sealant build-up on the slinger and string guard. It is advisable to replace the two bearings every time the brush is replaced.
5. Re-install the above components.  
**CAUTION!** Install shorter step on the shaft ends toward the left pulley side. Apply silicone sealant onto the ends of the brush core before re-assembling the slinger and string guard.

# GENERAL FAULT FINDING GUIDE

**CAUTION - Repairs should only be carried out by a QUALIFIED AND FULLY TRAINED PERSON !**

PROBLEM	POSSIBLE CAUSE
<b><i>ELECTRICAL SYSTEM</i></b>	
No electrical power	<ol style="list-style-type: none"> <li>1. Defective power cable</li> <li>2. House or building circuit breaker tripped</li> </ol>
Switch is turned on but power is intermittent to all motor(s).	<ol style="list-style-type: none"> <li>1. Faulty electrical cable</li> <li>2. Defective switches</li> <li>3. Loose "Molex" plug connector or terminal connections</li> </ol>
<b><i>VACUUM SYSTEM</i></b>	
No vacuum	<ol style="list-style-type: none"> <li>1. Vacuum lid is not resting on waste bucket(s)</li> <li>2. Loose vacuum hose or vacuum connection</li> </ol>
Low vacuum	<ol style="list-style-type: none"> <li>1. Accumulated dirt on lid screen</li> <li>2. Worn out vacuum lid gasket</li> <li>3. Lint &amp; dirt build-up on vacuum nozzle</li> <li>4. Defective vacuum hose</li> <li>5. Loose connection in the vacuum motor</li> </ol>
<b><i>SOLUTION SYSTEM</i></b>	
Pump motor is on but there is no spray	<ol style="list-style-type: none"> <li>1. Solution tank is empty</li> <li>2. Clogged spray tips</li> <li>3. Clogged solution tank filter</li> <li>4. Blocked female quick connector</li> <li>5. Damaged pump diaphragm</li> <li>6. Damaged or clogged pump check valve</li> <li>7. Leak from pump head</li> <li>8. Clogged or faulty solenoid valve</li> </ol>
Uneven or weak spray	<ol style="list-style-type: none"> <li>1. Partially clogged spray tips</li> <li>2. Partially clogged solution tank filter</li> <li>3. Partially clogged pump head or check valve</li> <li>4. Worn pump bearing (excessive noise)</li> <li>5. Damaged pump diaphragm</li> <li>6. Defective motor or rectifier</li> <li>7. Worn or damaged spray tip</li> </ol>
Solution drips form spray tips	<ol style="list-style-type: none"> <li>1. Debris caught in solenoid valve parts or plunger</li> </ol>
<b><i>BRUSH SYSTEM</i></b>	
Motor runs but brush does not turn	<ol style="list-style-type: none"> <li>1. Broken drive belt</li> <li>2. Brush jammed</li> <li>3. Loose pulley tension</li> </ol>
Floating brush won't move up or down	<ol style="list-style-type: none"> <li>2. Debris caught inside slide block guide</li> </ol>
Brush motor fails to turn on after circuit breaker has been reset	<ol style="list-style-type: none"> <li>3. Brush jammed</li> <li>4. Blown breaker</li> <li>5. Defective motor or rectifier</li> <li>6. Defective switch</li> <li>7. Loose wiring connection</li> </ol>

# SUPERNOVA FAULT FINDING GUIDE

**CAUTION - Repairs should only be carried out by a QUALIFIED AND FULLY TRAINED PERSON !**

PROBLEM	POSSIBLE CAUSE
<b>VACUUM VALVE</b>	
Vacuum valve, item (8) has an air flow leak	<ol style="list-style-type: none"> <li>1. Vacuum valve out of adjustment causing seal, item (15), to be incorrectly positioned. Re-adjust (see vacuum valve pull cable adjustment procedure)</li> <li>2. Damaged or worn vacuum valve seal, item (15)</li> <li>3. Broken vacuum valve pull cable, item (23)</li> <li>4. Loose or broken vacuum valve pull springs, item (25)</li> <li>5. Damaged vacuum valve guide face gasket, item (15)</li> <li>6. Damaged vacuum valve pressure balls, item (12), or vacuum valve pressure ball springs, item (13)</li> </ol>
Vacuum valve, item (8) not functioning	<ol style="list-style-type: none"> <li>1. Vacuum valve springs, item (25), not connected or broken</li> <li>2. Broken pull cable, item (23)</li> </ol>
<b>PULL CABLE MECHANISM</b>	
Direction control lever arm, item (20), does not lock in the up position	<ol style="list-style-type: none"> <li>1. One or both shaft collar set screws, item (22) are loose. Re-tighten set screws.</li> <li>2. Too much clearance between pull cable cam, item (18) and stop bracket item (28). Add spacers, item (17) as required to bring cam flush with stop bracket.</li> <li>3. Damaged plunger item (19)</li> </ol>
Pull cable item (23) jumps out of pull cable cam item (18) in down position	<ol style="list-style-type: none"> <li>1. Loose or broken vacuum valve springs item (25). Reconnect or replace springs.</li> <li>2. Vacuum valve item (8) is too low when in up position. Readjust (see vacuum valve pull cable adjustment procedure)</li> </ol>
<b>BRUSH MOTOR REVERSE</b>	
Brush motor fails to reverse when direction control lever arm, item (20) is in the up (backward) position.	<ol style="list-style-type: none"> <li>1. Vacuum valve item (8) does not reach its normal up position. Adjust the pull cable jacket, item (1) and switches, item (11) as shown in the adjustment instruction section.</li> <li>2. Defective reverse switch item (11)</li> <li>3. Loose switch connector, item (26). Check colour coding before re-connecting terminals. Replace wire assembly if necessary.</li> </ol>
Brush motor fails to reverse when direction control lever arm, item (20) is in the down (forward) position.	<ol style="list-style-type: none"> <li>1. Vacuum valve, item (8) does not reach its normal down position. Adjust the pull cable jacket, item (1) and switches, item (11) as shown in the adjustment instruction section. Remove any dirt or foreign objects from between the vacuum valve, item (16) in down position and the bumper, item (29). Replace vacuum valve springs, item (25) if broken or stretched.</li> <li>2. Defective reverse switch item (11)</li> <li>3. Loose switch connector, item (26). Check colour coding before re-connecting terminals. Replace wire assembly if necessary.</li> </ol>

# SUPERNOVA

## VACUUM VALVE AND BRUSH MOTOR REVERSE SWITCH ADJUSTMENT PROCEDURES

### VACUUM VALVE PULL CABLE ADJUSTMENT

1. Drain the solution tank and remove the recovery bucket(s) from the machine.
2. Make sure that the power cable is unplugged from the power socket.
3. Shift the direction control lever arm to the up (backward) position.
4. Open the motor housing by actuating the latch handle lever and locking screw(s) and lifting the motor housing from the front (for later models see instruction on page 13).
5. TO MOVE THE VACUUM VALVE ITEM (8) UP:  
Loosen the lower pull cable jacket nut, item (4)  
Tighten upper pull cable jacket nut, item (2) until the desired position is reached (in its normal position, the upper edge of the spring bracket, item (5) is flush with the upper edge of the vacuum valve guide, item (6)).  
Retighten lower cable jacket nut, item (4)
6. TO MOVE THE VACUUM VALVE ITEM (8) DOWN:  
Loosen the upper cable jacket nut, item (2) until the vacuum valve, item (8) reaches the desired position.  
Tighten the lower cable jacket nut, item (4)

### BRUSH MOTOR REVERSING SWITCH ADJUSTMENT

1. Drain the solution tank and remove the recovery bucket(s) from the machine.
2. Make sure that the power cable is unplugged from the power socket.
3. Shift the direction control lever arm to the up (backward) position.
4. Adjust the pull cable, if required, to ensure that the vacuum valve is in the correct position (see vacuum valve pull cable adjustment procedure)
5. TO MAKE THE ADJUSTMENT:  
Slightly loosen the two switch nuts, item (7) located on the switch bracket, item (9).  
Rotate the three switches by pushing their bodies, item (11) toward the timing bar plate, item (27) until the switch actuating arm rollers, item (10) touch the timing bar plate.  
While holding the switches, item (11) in position, retighten the two switch nuts, item (7).

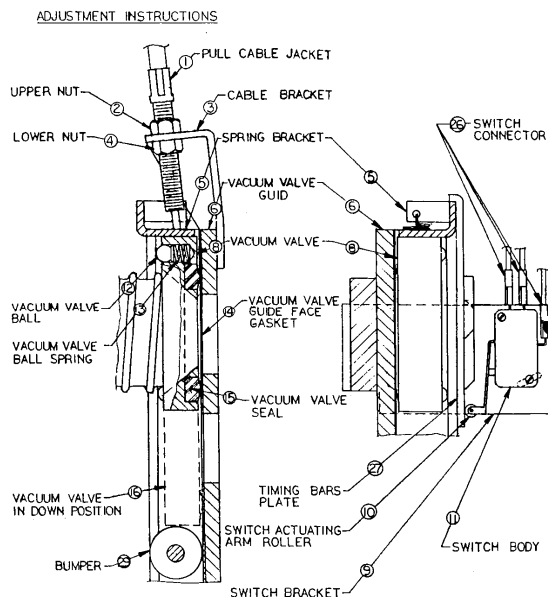
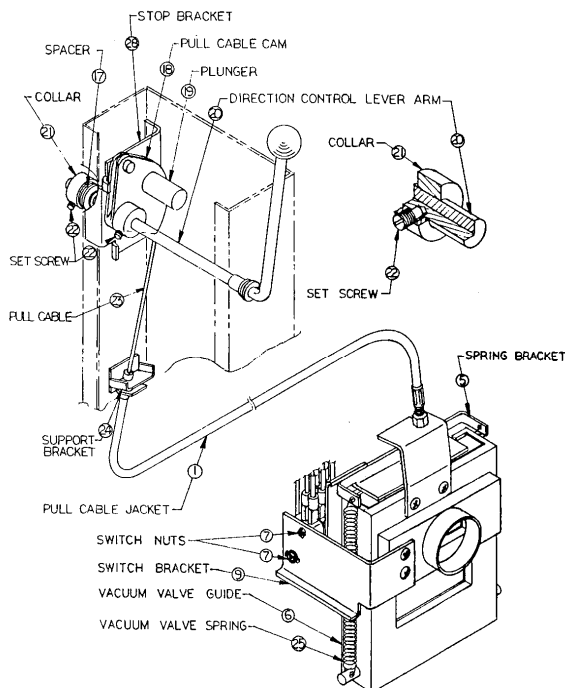

# POLARIS 500, POLARIS 700 & SUPERNOVA 700 PARTS LIST

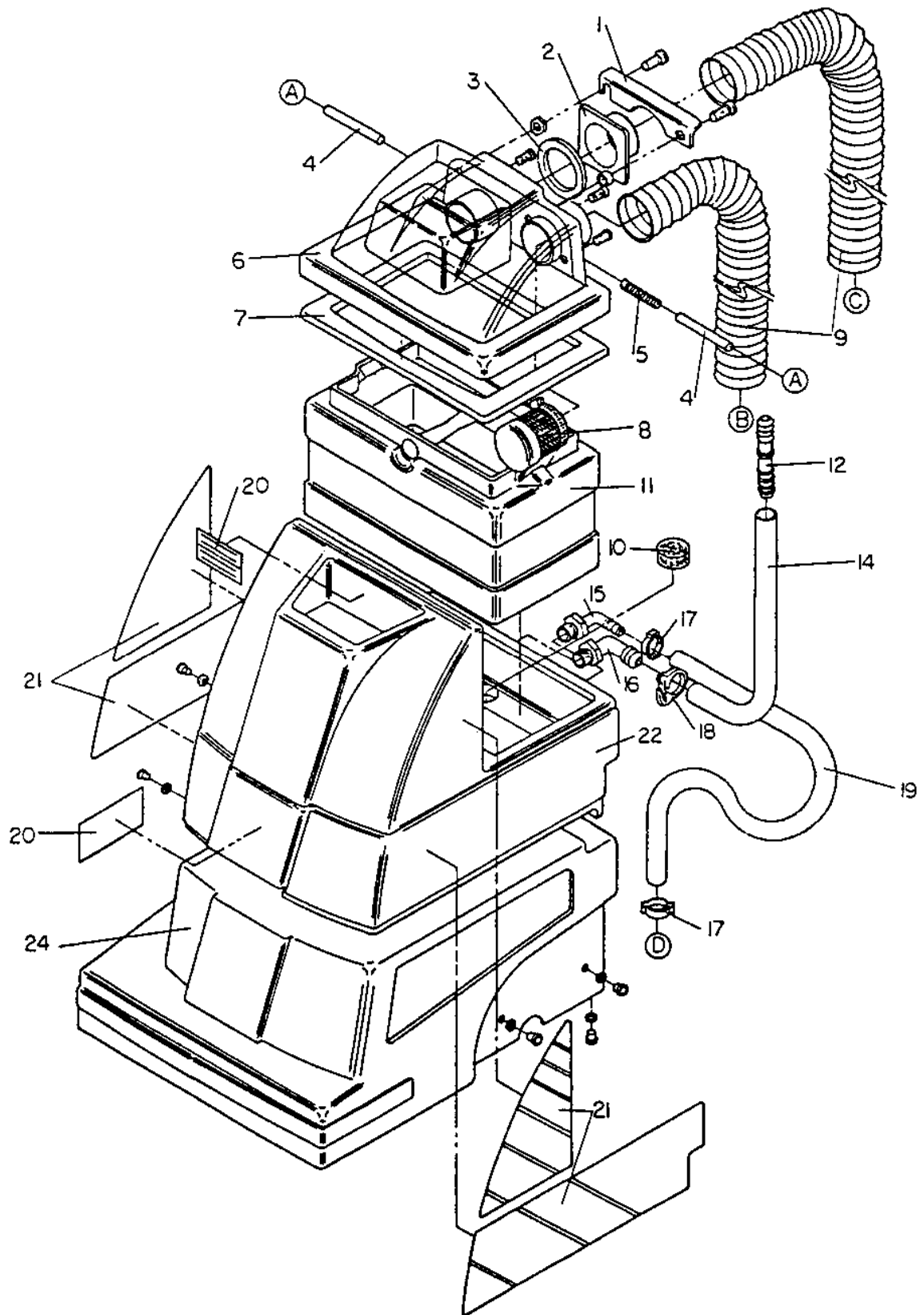

**MAIN BODY ASSEMBLY**

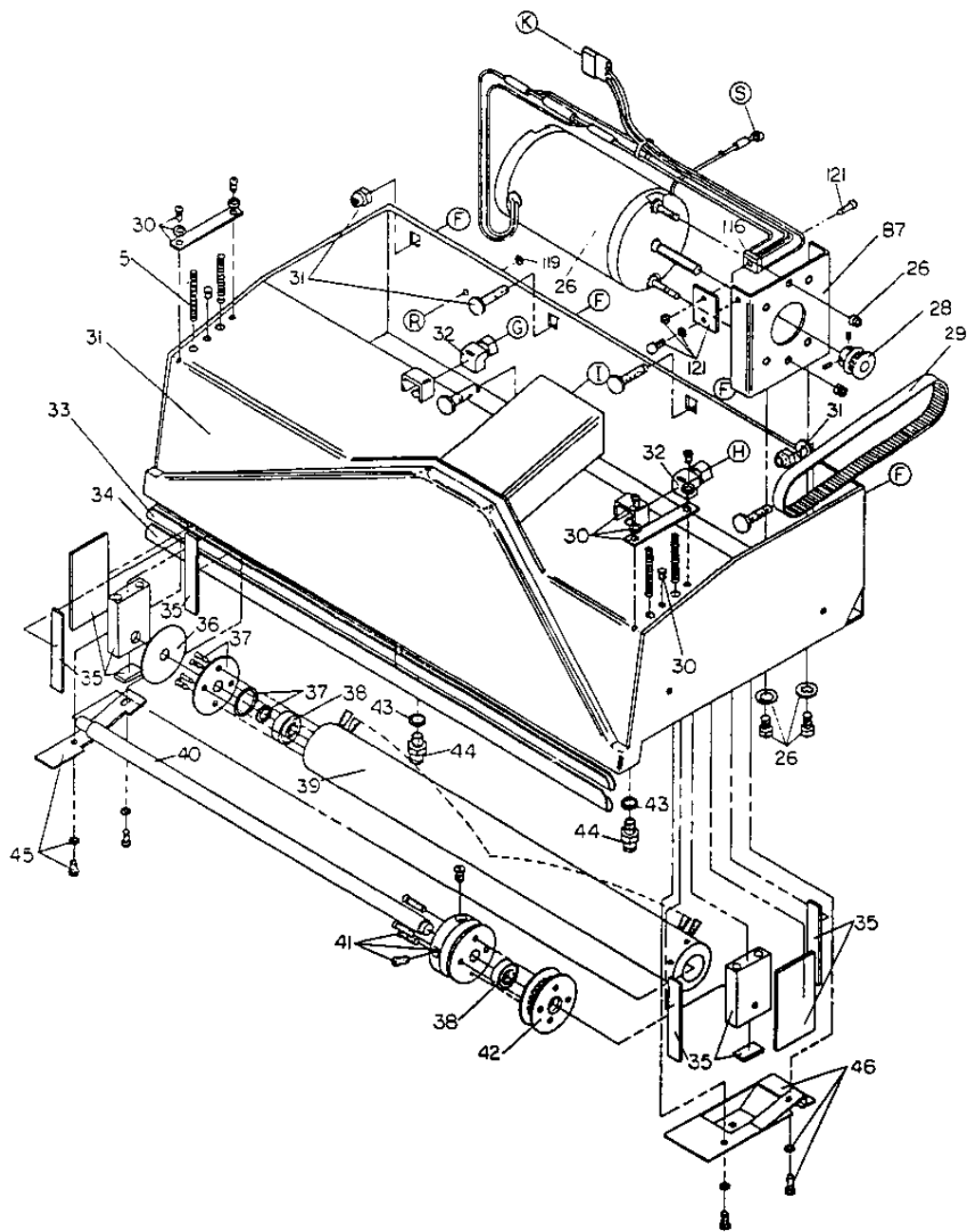

**POLARIS 500 & 700  
BRUSH HOUSING ASSEMBLY**



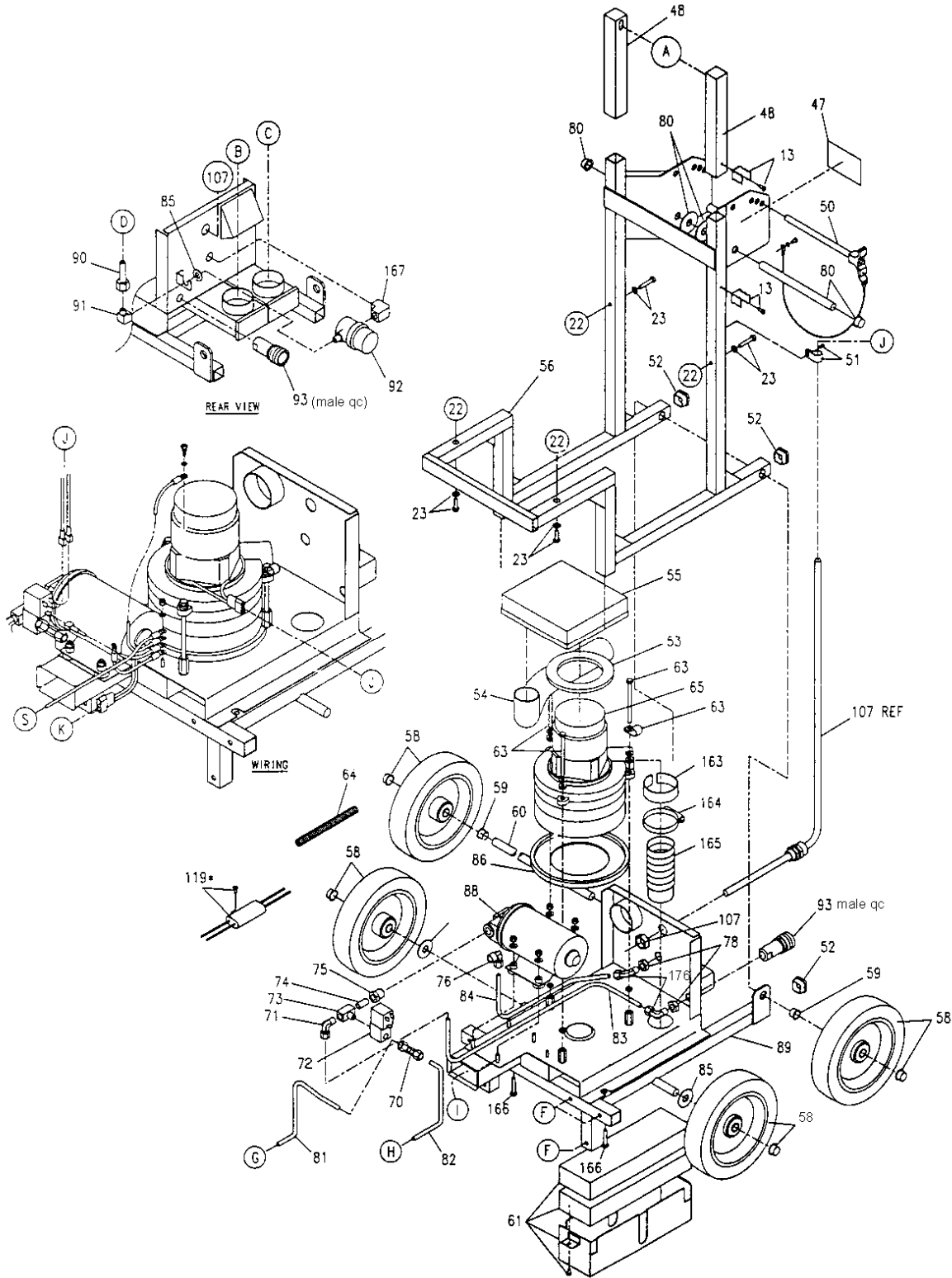

**POLARIS 500, POLARIS 700 & SUPERNOVA 700  
MOTOR HOUSING ASSEMBLY**

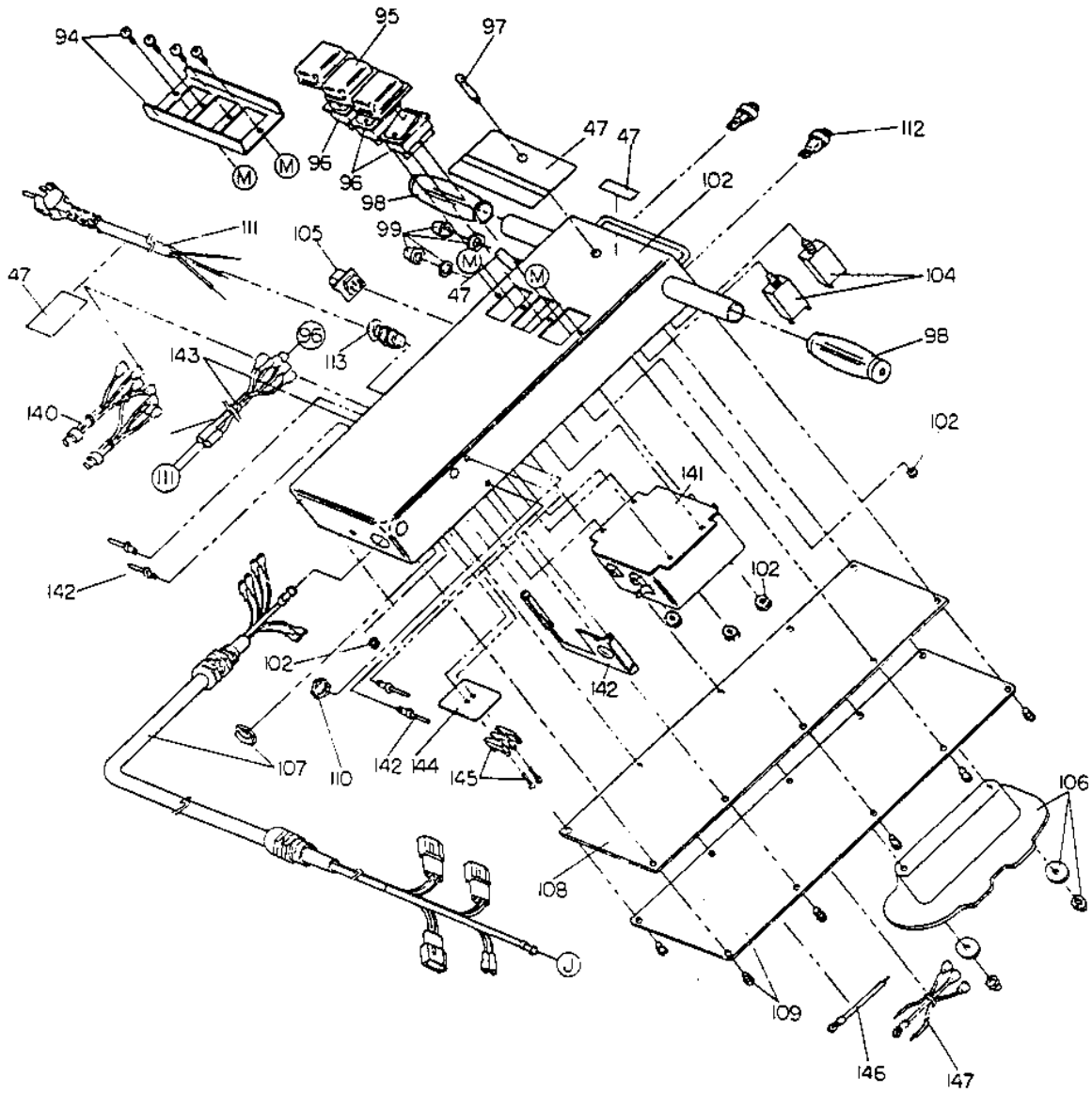

**POLARIS 500, POLARIS 700 & SUPERNOVA 700  
HANDLE ASSEMBLY**

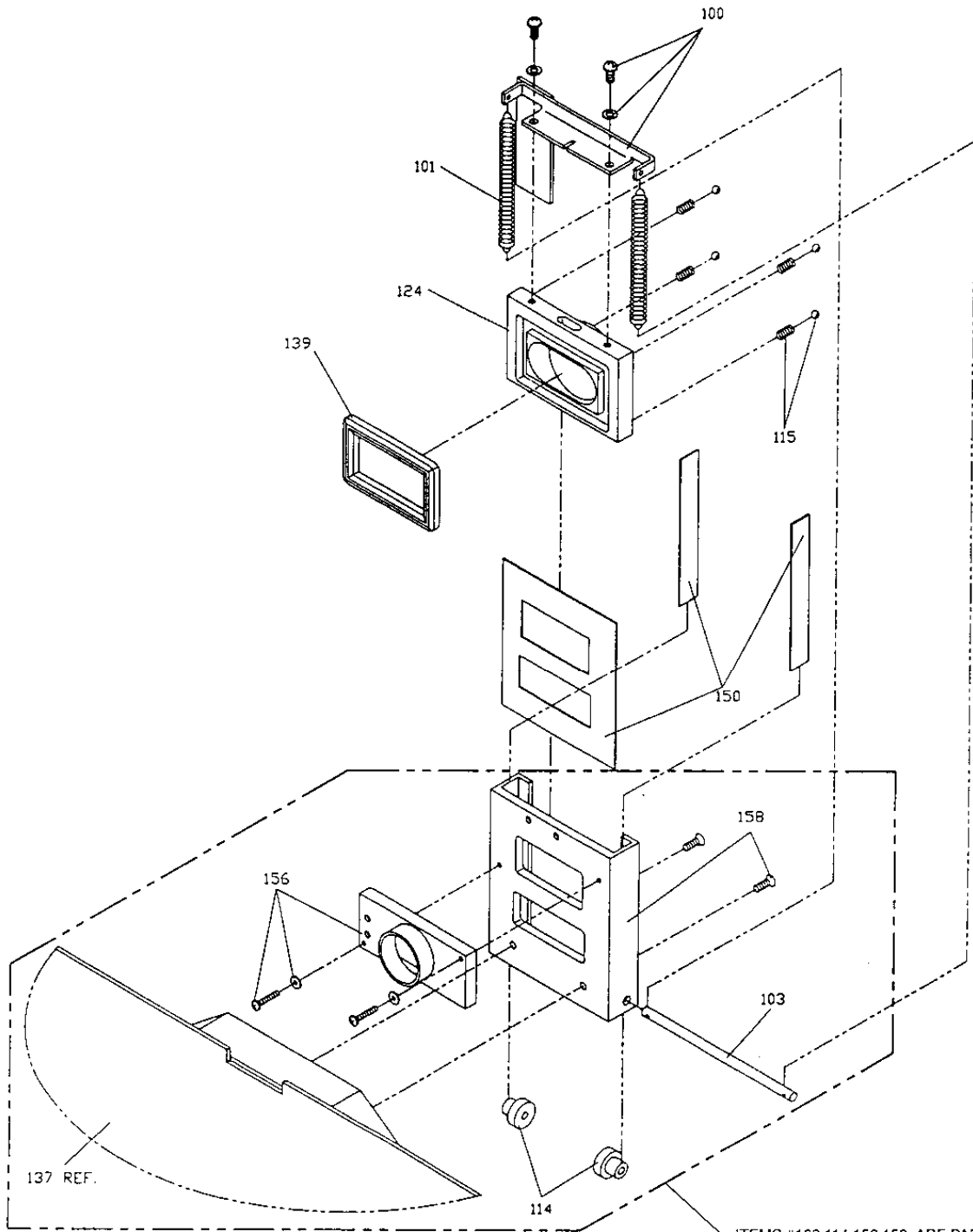

ITEMS #103,114,156,158 ARE PART OF  
 FLOATING HEAD REAR ASSEMBLY,  
 ITEM #137 (SEE FIG. 3).

**SUPERNOVA 700**

**SUPERNOVA 700  
 VACUUM VALVE ASSEMBLY**

# POLARIS 500 & 700 PARTS LIST

REF.	STOCK CODE	PART NO.	DESCRIPTION	QTY
1		D02391	CLIP, ADAPTER RETAINER	1
2	E02359	D02359	HOSE ADAPTER	1
3	E02431	E02431	SEAL, VACUUM INTAKE	1
4		D02373-1	SHAFT, LID PIVOT 3 7/8" x 5/16"	2
5	E02372	D02372	SPRING DOME PIVOT & SLIDE BLOCK	5
6	E00491-1A	80491-1A	VACUUM LID ASSEMBLY	1
7	E03431	E03431	GASKET, VACUUM LID	1
8	E82407A	82407A	FILTER SCREEN ASSEMBLY, VACUUM LID	1
9	E00618	J00618	HOSE, VACUUM, 2" ID	2
10		L00767	PLUG, SOLUTION TANK	1
11	E02456-7	F02465-7	RECOVERY PAIL, POLARIS 500	1
	E02456-6	F02465-6	RECOVERY PAIL, POLARIS 700	1
12		A00165	DRAIN NOZZLE, 1/2" BARB X 1/2" BARB	1
13		80263-3A	CLIP ASSEMBLY, DRAIN HOSE	2
14		J00598	DRAIN HOSE, 5/8" OD X 1/8" WALL	1
15	E00138	A00138	90 ELBOW 1/2" MP X 3/8" BARB	1
16	E00099	A00099	90 ELBOW 1/2" MP X 5/8" BARB	1
17	TT00640	J00637	HOSE CLAMP 5/8"	2
18		J00652	HOSE CLAMP 7/8"	1
19	E00613	J00613	SOLUTION HOSE 3/8" ID	1
20		82570-1A	LABEL KIT	1
21		H02561	DECAL KIT, POLARIS 500	1
		H02552	DECAL KIT, POLARIS 700	1
22	E02463-10	F02463-10	SOLUTION TANK ASSEMBLY, POLARIS 500	1
	E02463-9	F02463-9	SOLUTION TANK ASSEMBLY, POLARIS 700	1
22	E90008	F90008	FILTER WITH FRAME	1
23		82310A	SOLUTION TANK MOUNTING KIT	1
24		F02470-3	HOUSING, MOTOR, POLARIS 500	1
	E02406	F02470-2	HOUSING, MOTOR, POLARIS 700	1
26	E02538-1	11-209-03	BRUSH DRIVE MOTOR ASSEMBLY 220-240V	1
27		00185-6A	WIRE ASSEMBLY GROUND, BRUSH MOTOR	1
		00185-6A	WIRE ASSEMBLY GROUND, VACUUM MOTOR	1
28	E00398-1	D00398-A	PULLEY, BRUSH DRIVE MOTOR	1
29	E00779-1	L00779-1	DRIVE BELT POLARIS (140XL)	1
30		82378A	COVER PLATE ASSEMBLY, SPRING	1
31		82405A	BRUSH CHAMBER ASSEMBLY, POLARIS 500	1
		82406A	BRUSH CHAMBER ASSEMBLY, POLARIS 700	1
32	E00144	A00144	90 ELBOW 1/8" FP X 1/4"C	2
33	E02388-1	D02388-1	GLIDE, BACK POLARIS 500	1
	E02389-1	D02389-1	GLIDE, BACK POLARIS 700	1
34	E02388	D02388	GLIDE, FRONT POLARIS 500	1
	E02389	D02389	GLIDE, FRONT POLARIS 700	1
35	E80500A	80500A	SLIDE BLOCK ASSEMBLY (INCL SPRINGS & PTFE SLIDES)	2
36	E00504	F00504	WASHER, SLIDE BLOCK 1/16" x 25/64" x 2"	1
37	E82235A	82235A	STRING GUARD ASSEMBLY	1
38	E00536B	G00536	BEARING, BRUSH	2
39	E02475	F02475	BRUSH, ROTARY POLARIS 500	1
	E02476	F02476	BRUSH, ROTARY POLARIS 700	1
40	E02386	D02386	SHAFT, BRUSH POLARIS 500	1
	E02387	D02387	SHAFT, BRUSH POLARIS 700	1
41	E82376A	82376A	SLINGER ASSEMBLY, ROTARY BRUSH	1
42	E00398-2	D00398-2	PULLEY, ROTARY BRUSH	1
43	E02298	C02298	WASHER, 3/32" X 7/16" X 5/8" (14")	1
	E02298	C02298	WASHER, 3/32" X 7/16" X 5/8" (17")	2
44	E00091	A00091-1	SPRAY TIP 110 08 POLARIS 500	1
	E00090	A00091	SPRAY TIP 110 04 POLARIS 700	2
45	E82368A	82368A	COVER PLATE ASSEMBLY, OPEN END	1
46	E02367	82367A	COVER PLATE ASSEMBLY, PULLEY END	1
47		H00563	LABEL KIT, ENGLISH	1
48		D02344-1	PIVOT EXTENSION LID FRAME (500)	2
		D02344	PIVOT EXTENSION LID FRAME (700)	2
50		82383A	PIN ASSEMBLY, RETAINING	1
51		80187A	CLAMP ASSEMBLY, CORD	1
52	E00712-4	K00712-4	CAP, END	4
53		E02450	GASKET, COOLING AIR DUCT	1

REF.	STOCK CODE	PART NO.	DESCRIPTION	QTY
54	E00654	J00654	HOSE, EXHAUST 2"	1
55		D02394	DUCT, COOLING AIR	1
56		D02397	FRAME UPPER	1
58	E82535A	82535A	WHEEL ASSEMBLY	4
	E02305	C02305	CAP, PUSH-ON 1/2"	4
59		K00674	BUSHING	2
60		D02398	AXLE, WHEEL	1
61		81331A	MUFFLER KIT	1
63		82291A	VACUUM MOTOR MOUNTING ASSEMBLY	1
64		F00463	LOOM, CORRUGATED	1
65	LA4503P	117148-13	VACUUM MOTOR, 2 STAGE 220-240V REVERSE FAN	1
70	E00125	A00125	BUSHING 1/8"MP X 1/4"C (POLARIS 500)	1
	E00153	A00153	MALE RUN TEE, 1/8" NPT X 1/4"C (POLARIS 700)	1
71	E00132	A00132	90 ELBOW 1/8"MP X 1/4"C	1
72	E02532-1	G02537	SOLENOID, 1/8"NPT 220-240V	1
73	E00152	A00152	BRANCH TEE, MALE 1/8"NPT	1
74	E00055	A00055	NIPPLE, SHORT 1/8"NPT	1
75	PC800111	11-800111	BUSHING, REDUCER, 3/8" X 1/8" NPT	1
76	E00133	A00133	90 ELBOW 3/8"MP X 1/4"C	1
78	E00124	A00124	NUT, HEX	2
80		80418-6A	SHAFT ASSEMBLY, HANDLE	1
81		A00085-9	TUBE, SOLENOID TO SPRAY TIP 17" (700)	1
82		A00085-12	TUBE, SOLENOID TO SPRAY TIP 14" (500)	1
83		A00085-10	TUBE, PUMP TO ACCESSORY LINE	1
84		A00085-11	TUBE, PUMP TO SOLUTION INTAKE LINE	1
85	E00240	C00240	SPACER, 3/16" X 1/2" X 1" OD	3
86	E02448	E02448	GASKET, VACUUM MOTOR	1
87		D02370	BRACKET, BRUSH DRIVE MOTOR	1
88	E10763-1 FJ4401B	8090-951-250 S2100818A	SHURFLO PUMP 230V FLOJET PUMP 230V	1 1
89		82359A	LOWER FRAME ASSEMBLY	1
90	E00061	A00061	ADAPTER, 3/8" BARB X 1/4" FP	1
91	E00052	A00052	90 ELBOW, 1/4"FP X 1/4"MP	1
92	E00709	K00709	FILTER STRAINER, IN-LINE	1
	E00709-1	K00709-1	SCREEN, IN-LINE STRAINER	1
	E00709-2	K00709-2	CAP, IN-LINE STRAINER	1
	E00709-3	K00709-3	GASKET (SEAL) IN-LINE STRAINER	1
93	GU00104	B2-K16	QUICK DISCONNECT 1/4"FP MALE	1
94		82414A	SWITCH GUARD ASSEMBLY	1
95	E00214-2	B00214-2	COVER, ROCKER SWITCH	3
96	E02211-1	B02211-1	ROCKER SWITCH, ILLUMINATED	3
97	E02190	B02196	LIGHT, INDICATOR, GREEN LENS	1
98	AI00715	K00715B-1	GRIP HANDLE, BLACK	2
99	E02193	B02193	BOOT, FLEX, CIRCUIT BREAKER	1
102		D02403	HANDLE, ADJUSTABLE	1
104	E02191	B02192	CIRCUIT BREAKER, 3A	1
105		80188A	OUTLET ASSEMBLY, ACCESSORY (NOT FITTED)	1
106		82408A	CORD WRAP ASSEMBLY	1
107	E00185-32A	00185-28A	CORD ASSEMBLY, HANDLE TO LOWER FRAME	1
108		E03432	GASKET, HANDLE	1
109		82409A	COVER PLATE ASSEMBLY	1
110		B02214	LOCK NUT	1
111	BE4901	B00225	POWER CORD EC 220-240V 1.5MM	1
112	E02187	B02187	TOGGLE SWITCH (EARLIER VERSION)	1
	RS4902	233-3936	TOGGLE SWITCH COVER (EARLIER VERSION)	1
	E02173	B02173	SWITCH, PUSH BUTTON (LATER VERSION)	2
113	E11199	B11199	STRAIN RELIEF, POWER CORD	1
			CORD ANCHOR (NOT SHOWN)	1
116	RS5218		RECTIFIER (REPLACES E00843)	1
121		802171A	MOUNTING BOARD	1
163		E02441	GASKET HORN	1
164	TT00639	J00639	HOSE CLAMP	1
165		800618A	HOSE ASSEMBLY, VACUUM EXHAUST	1
166	E02322	C02322	SCREW, MACHINE HEX HEAD, 1/4"-20 X 1 3/4"	2
	JE00233	C00233	WASHER, FLAT 1/4"	2
	JE00254	C00254	WASHER, SPRING 1/4"	2
167		A00154	90 ELBOW, 1/4"FP X 1/4"FP	1
176	E00140	A00140	90 ELBOW 1/4" MP X 1/4" C	2
	E90001A	B90001	FILTER EMI - RFI 250V	1

# SUPERNOVA 700 PARTS LIST

REF.	STOCK CODE	PART NO.	DESCRIPTION	QTY
1		D02391	CLIP, ADAPTER RETAINER	1
2	E02359	D02359	HOSE ADAPTER	1
3	E02431	E02431	SEAL, VACUUM INTAKE	1
4		D02373-1	SHAFT, LID PIVOT 3 7/8" X 5/16"	2
5	E02372	D02372 D010159	SPRING DOME PIVOT SPRING, SLIDE BLOCK	1 4
6	E00491-1A	80491-1A	VACUUM LID ASSEMBLY	1
7	E03431	E03431	GASKET, VACUUM LID	1
8	E82407A	82407A	FILTER SCREEN ASSEMBLY, VACUUM LID	1
9	E00618	J00618	HOSE, VACUUM, 2" ID	2
10		L00767	PLUG, SOLUTION TANK	1
11	E02456-6	F02465-6	RECOVERY PAIL, 700	1
12		A00165	DRAIN NOZZLE, 1/2" BARB X 1/2" BARB	1
13		80263-3A	CLIP ASSEMBLY, DRAIN HOSE	2
14		J00598	DRAIN HOSE, 5/8" OD X 1/8" WALL	1
15	E00138	A00138	90 ELBOW 1/2" MP X 3/8" BARB	1
16	E00099	A00099	90 ELBOW 1/2" MP X 5/8" BARB	1
17	TT00640	J00637	HOSE CLAMP 5/8"	2
18		J00652	HOSE CLAMP 7/8"	1
19	E00613	J00613	SOLUTION HOSE 3/8" ID	1
20		82570-1A	LABEL KIT	1
21		H02552	DECAL KIT, 700	1
22	E02463-9	F02463-9	SOLUTION TANK ASSEMBLY, 700	1
22	E90008	F90008	FILTER WITH FRAME	1
23		82310A	SOLUTION TANK MOUNTING KIT	1
24		F02470-6	HOUSING, MOTOR, SUPERNOVA 700	1
26	E02538-1	82523A	BRUSH DRIVE MOTOR ASSEMBLY 220-240V	1
27		00185-6A	WIRE ASSEMBLY GROUND, BRUSH MOTOR	1
		00185-6A	WIRE ASSEMBLY GROUND, VACUUM MOTOR	1
28	E00398-6	D00398-6	PULLEY, BRUSH DRIVE MOTOR	1
29	E00779-160	L00779	DRIVE BELT, SUPERNOVA (160XL)	1
30		D010154	COVER PLATE ASSEMBLY, SPRING	1
31		D010055	BRUSH CHAMBER ASSEMBLY, SUPERNOVA 700	1
32	E00144	A00144	90 ELBOW 1/8" FP X 1/4"C	2
33		D010076	GLIDE, BACK 17" SUPERNOVA 700	2
34		D010075	GLIDE, FRONT 17" SUPERNOVA 700	2
35	E80500A	80500A	SLIDE BLOCK ASSEMBLY (INCL SPRINGS & PTFE SLIDES)	2
36	E00504	F00504	WASHER, SLIDE BLOCK 1/16" x 25/64" x 2"	1
37	E82235A	82235A	STRING GUARD ASSEMBLY	1
38	E00536B	G00536	BEARING, BRUSH	2
39		F010057	BRUSH, ROTARY 17" SUPERNOVA 700	1
40	E02387	D02387	SHAFT, BRUSH 700	1
41	E82376A	82376A	SLINGER ASSEMBLY, ROTARY BRUSH	1
42	E00398-2	D00398-2	PULLEY, ROTARY BRUSH	1
43	E02298	C02298	WASHER, 3/32" X 7/16" X 5/8" (17")	4
44	E00089	A00089	SPRAY TIP 110 02	4
45		810152A	COVER PLATE ASSEMBLY, OPEN END	1
46		810153A	COVER PLATE ASSEMBLY, PULLEY END	1
47		83547A	LABEL KIT, ENGLISH	1
48		D02344	PIVOT EXTENSION LID FRAME (700)	2
50		82383A	PIN ASSEMBLY, RETAINING	1
51		80187A	CLAMP ASSEMBLY, CORD	1
52	E00712-4	K00712-4	CAP, END	4
53		E02450	GASKET, COOLING AIR DUCT	1
54	E00654	J00654	HOSE, EXHAUST 2"	1
55		D02394	DUCT, COOLING AIR	1
56		D010074	FRAME UPPER	1
58	E82535A	82535A	WHEEL ASSEMBLY	4
	E02305	C02305	CAP, PUSH-ON 1/2"	4
59		K00674	BUSHING	2
60		D02398	AXLE, WHEEL	1
61		81331A	MUFFLER KIT	1
63		82291A	VACUUM MOTOR MOUNTING ASSEMBLY	1
64		F00463	LOOM, CORRUGATED	1
65	LA4503P	117148-13	VACUUM MOTOR, 2 STAGE 220-240V REVERSE FAN	1

REF.	STOCK CODE	PART NO.	DESCRIPTION	QTY
70	E00153	A00153	MALE RUN TEE 1/8" NPT X 1/4"C	1
71	E00132	A00132	90 ELBOW 1/8"MP X 1/4"C	1
72	E02532-1	G02537	SOLENOID, 1/8"NPT 220-240V	1
73	E00152	A00152	BRANCH TEE, MALE 1/8"NPT	1
74	E00055	A00055	NIPPLE, SHORT 1/8"NPT	1
75	PC800111	11-800111	BUSHING, REDUCER, 3/8" X 1/8" NPT	1
76	E00133	A00133	90 ELBOW 3/8"MP X 1/4"C	1
78	E00124	A00124	NUT, HEX	2
80		80418-6A	SHAFT ASSEMBLY, HANDLE	1
81		A00085-17	TUBE, SOLENOID TO SPRAY TIP 17" (700)	1
83		A00085-19	TUBE, PUMP TO ACCESSORY LINE	1
84		A00085-20	TUBE, PUMP TO SOLUTION INTAKE LINE	1
85	E00240	C00240	SPACER, 3/16" X 1/2" X 1" OD	3
86	E02448	E02448	GASKET, VACUUM MOTOR	1
87		D03385	BRACKET, BRUSH DRIVE MOTOR	1
88	E10763-1 FJ4401B	8090-951-250 S2100818A	SHURFLO PUMP 230V FLOJET PUMP 230V	1 1
89		810070A	LOWER FRAME ASSEMBLY	1
90	E00061	A00061	ADAPTER, 3/8" BARB X 1/4" FP	1
91	E00052	A00052	90 ELBOW, 1/4"FP X 1/4"MP	1
92	E00709	K00709	FILTER STRAINER, IN-LINE	1
	E00709-1	K00709-1	SCREEN, IN-LINE STRAINER	1
	E00709-2	K00709-2	CAP, IN-LINE STRAINER	1
	E00709-3	K00709-3	GASKET (SEAL) IN-LINE STRAINER	1
93	GU00104	A00104	QUICK DISCONNECT 1/4"FP MALE	1
94		82414A	SWITCH GUARD ASSEMBLY	1
95	E00214-2	B00214-2	COVER, ROCKER SWITCH	3
96	E02211-1	B02211-1	ROCKER SWITCH, ILLUMINATED	3
97	E02190	B02196	LIGHT, INDICATOR, GREEN LENS	1
98	A100715	K00715B-1	GRIP HANDLE, BLACK	2
99	E02193	B02193	BOOT, FLEX, CIRCUIT BREAKER	1
100		83349A	SPRING, BRACKET, VACUUM VALVE ASSEMBLY	1
101		D03371	SPRING, VACUUM VALVE SLIDE RETURN	2
102		D02338-2	HANDLE, ADJUSTABLE	1
103		D03356	SHAFT, VACUUM VALVE	1
104		B02192-1	CIRCUIT BREAKER, 4A	1
105		80188A	OUTLET ASSEMBLY, ACCESSORY (NOT FITTED)	1
106		82408A	CORD WRAP ASSEMBLY	1
107		B010090	CORD ASSEMBLY, HANDLE TO LOWER FRAME	1
108		E03432	GASKET, HANDLE	1
109		82409A	COVER PLATE ASSEMBLY	1
110		B02214	LOCK NUT	1
111	BE4901	B00225	POWER CORD EC 220-240V 1.5MM	1
112	E02173	B02173	SWITCH, PUSH BUTTON	2
113	E11199	B11199	STRAIN RELIEF, POWER CORD	1
			EXTERNAL CORD ANCHOR (NOT SHOWN)	1
114		E03435	BUMPER, VACUUM VALVE	2
115		83372A	SPRING AND BALL KIT	1
116	RS5218		RECTIFIER	1
119	RS5201	B02175	EMC / RFI FILTER ASSEMBLY 240V	1
120	E00185-32A	00185-31A	HARNESS RECTIFIER 240V	1
121		802202A	MOUNTING BOARD	1
122	E00657	J00657	CLAMP, 2 1/8 x 2 3/8	2
123	E00621	J00621	HOSE, AIR VALVE ASSEMBLY 5"	1
124		D03364	SLIDE, VACUUM VALVE ASSEMBLY	1
125		83382A	BRACKET, FRONT, PULL CABLE ASSEMBLY	1
126		83383A	SWITCH BRACKET ASSEMBLY	1
127	E02172	B02172	SWITCH, MOTOR REVERSE	3
128		A00085-15	TUBE, TIP CONNECTOR	2
129		A00156	BRANCH TEE, FEMALE	2
130		83374A	FLOATING HEAD RETAINING PIN ASSEMBLY	1
131		80465A	GLIDE, SIDE	1
132		83361A	ADAPTER, FRONT HEAD	1
133	E00618-1	J00618-1	HOSE, FRONT HEAD ASSEMBLY, 1 1/2"	1
134		J00656	CLAMP 1 1/4 X 1 7/16"	2
135		H03561	LABEL, TWO-WAY	1
136		810078A	FLOATING HEAD, FRONT	1
137		810072A	FLOATING HEAD, REAR ASSEMBLY	1
138	E00464	F00464	BUTTON, GLIDE	8

REF.	STOCK CODE	PART NO.	DESCRIPTION	QTY
139	E03434	E03434	SEAL, SLIDE BLOCK	1
140		E00185-38A	WIRE CONNECTOR ASSEMBLY, HANDLE, JUMPER	1
141	E90001A	B90001	FILTER EMI - RFI 250V	1
142			NOT USED	1
143		00185-35A	HARNESS, POWER CORD TO SWITCHES 240V	1
144		B02195	INSULATOR, TERMINAL BLOCK 250V (TUV)	1
145		B02190	TERMINAL BLOCK 250V (TUV)	1
146		00185-39A	HARNESS, TERMINAL BLOCK TO EARTH POINT	1
147		00185-36A	HARNESS, TERMINAL BLOCK TO RFI FILTER (TUV)	1
148	E03350	D03350	STOP BRACKET	1
149	E83346A	83346A	CAM WITH PLUNGER, PULL CABLE	1
150	E80459A	80459A	GASKET, VACUUM VALVE GUIDE	1
151		K02716	CAP, PROTECTIVE	1
152		C02277	COLLAR, SHAFT, 3/8 ID	1
153		C02287	WASHER, TEFLON 3/8 ID	2
154		K00678	BUSHING 3/8 ID	2
155	E03347	D03347	LEVER ARM	1
156		D03363	ADAPTER PLATE, VALVE GUIDE	1
157		83357A	CLIP, PULL CABLE ASSEMBLY	1
158		D03345	GUIDE, VACUUM VALVE ASSEMBLY	1
159		K02712	KNOB, BALL	1
160	E00449	E00449	GROMMET	2
161		D03369	CABLE	1
162		00185-42A	HARNESS, SWITCHES	1
163		E02441	GASKET HORN	1
164	TT00639	J00639	HOSE CLAMP	1
165		800618A	HOSE ASSEMBLY, VACUUM EXHAUST	1
166	E02322	C02322	SCREW, MACHINE HEX HEAD, 1/4"-20 X 1 3/4"	2
	JE00233	C00233	WASHER, FLAT 1/4"	2
	JE00254	C00254	WASHER, SPRING 1/4"	2
167		A00154	90 ELBOW, 1/4"FP X 1/4"FP	1
176	E00140	A00140	90 ELBOW 1/4" MP X 1/4" C	2

# POLARIS & SUPERNOVA 800 & 1200 PARTS LIST

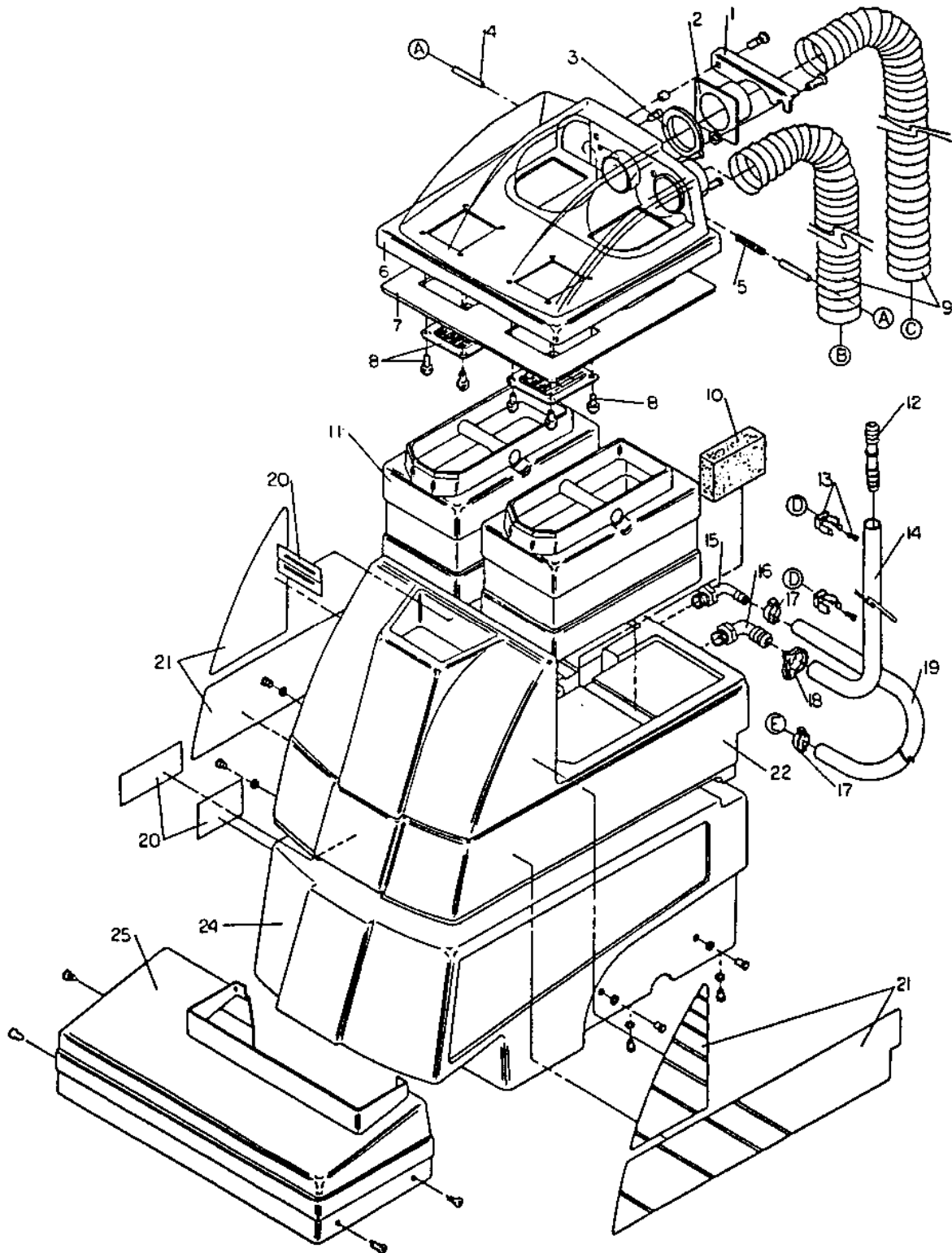

**MAIN BODY ASSEMBLY**

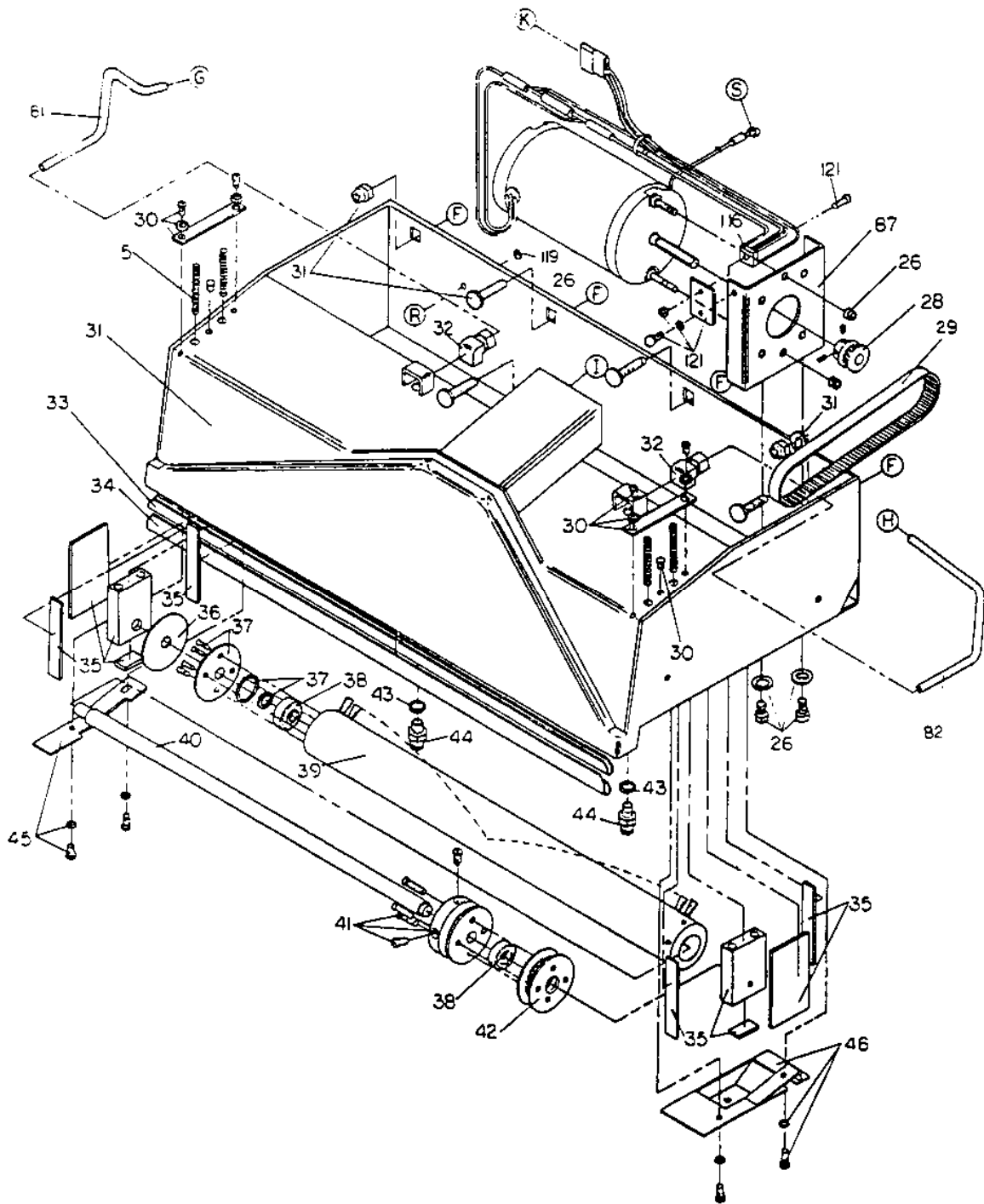

**POLARIS 800 & 1200  
BRUSH HOUSING ASSEMBLY**

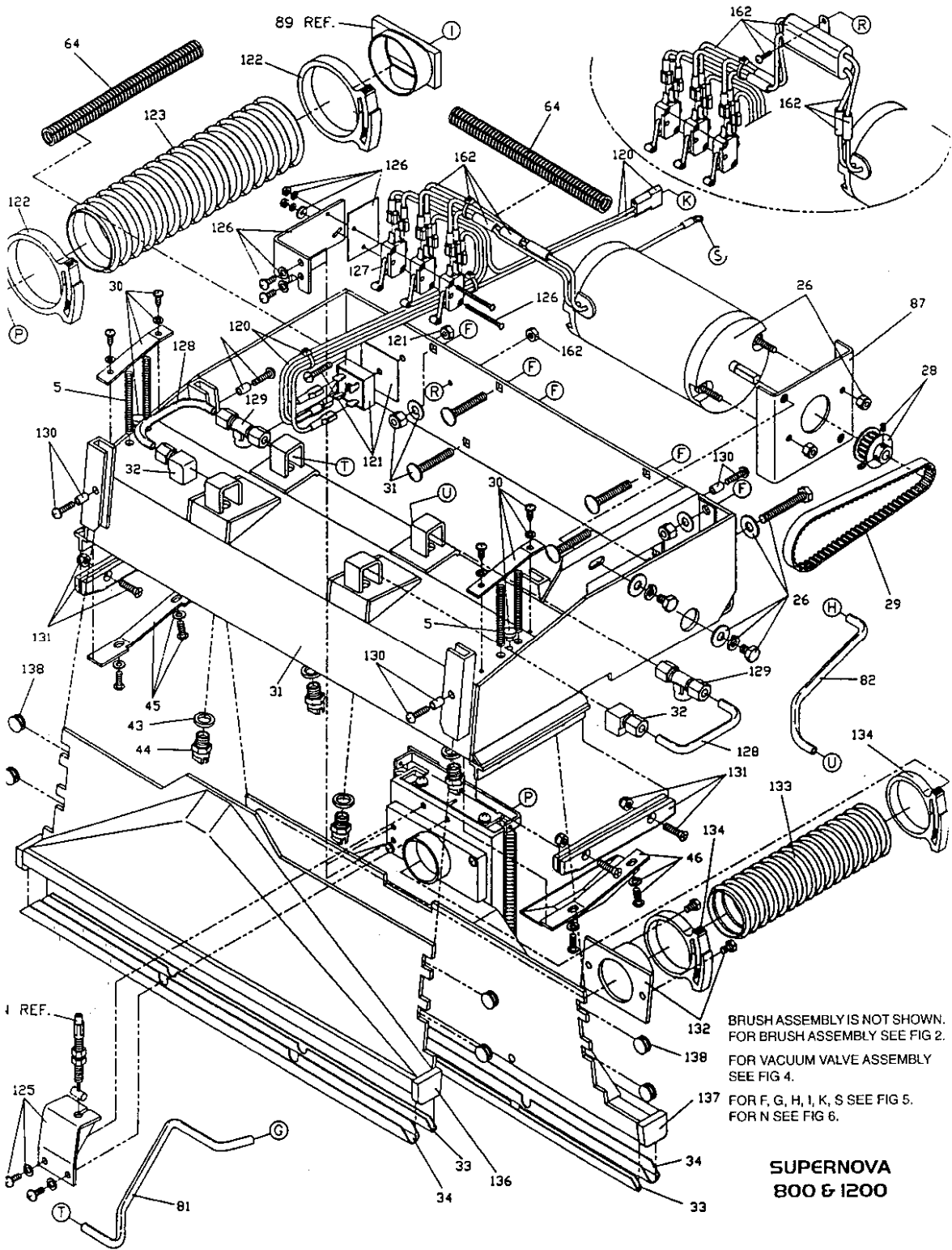

**SUPERNOVA 800 & 1200  
BRUSH HOUSING ASSEMBLY**

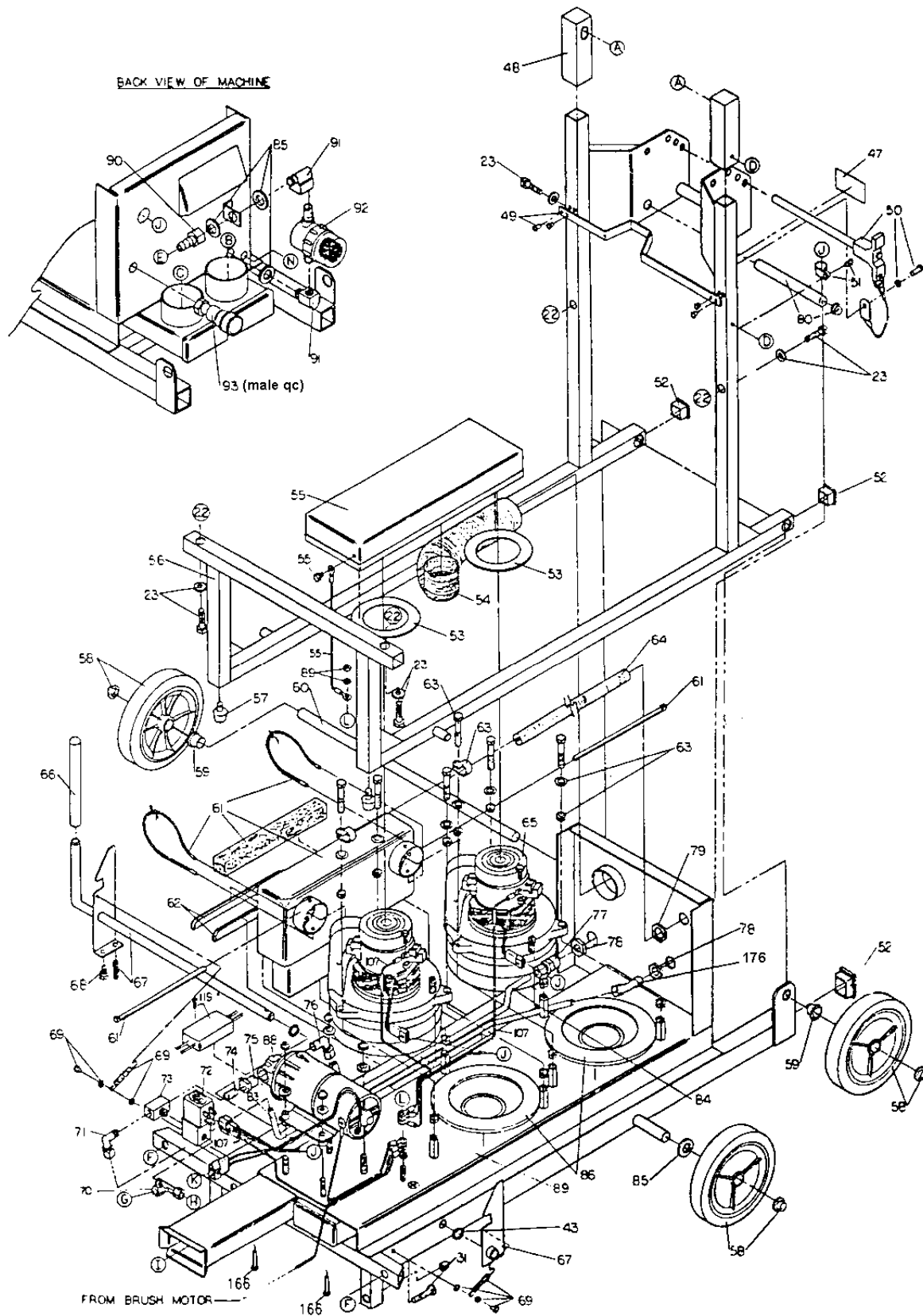

**POLARIS & SUPERNOVA 800 & 1200  
MOTOR HOUSING ASSEMBLY**

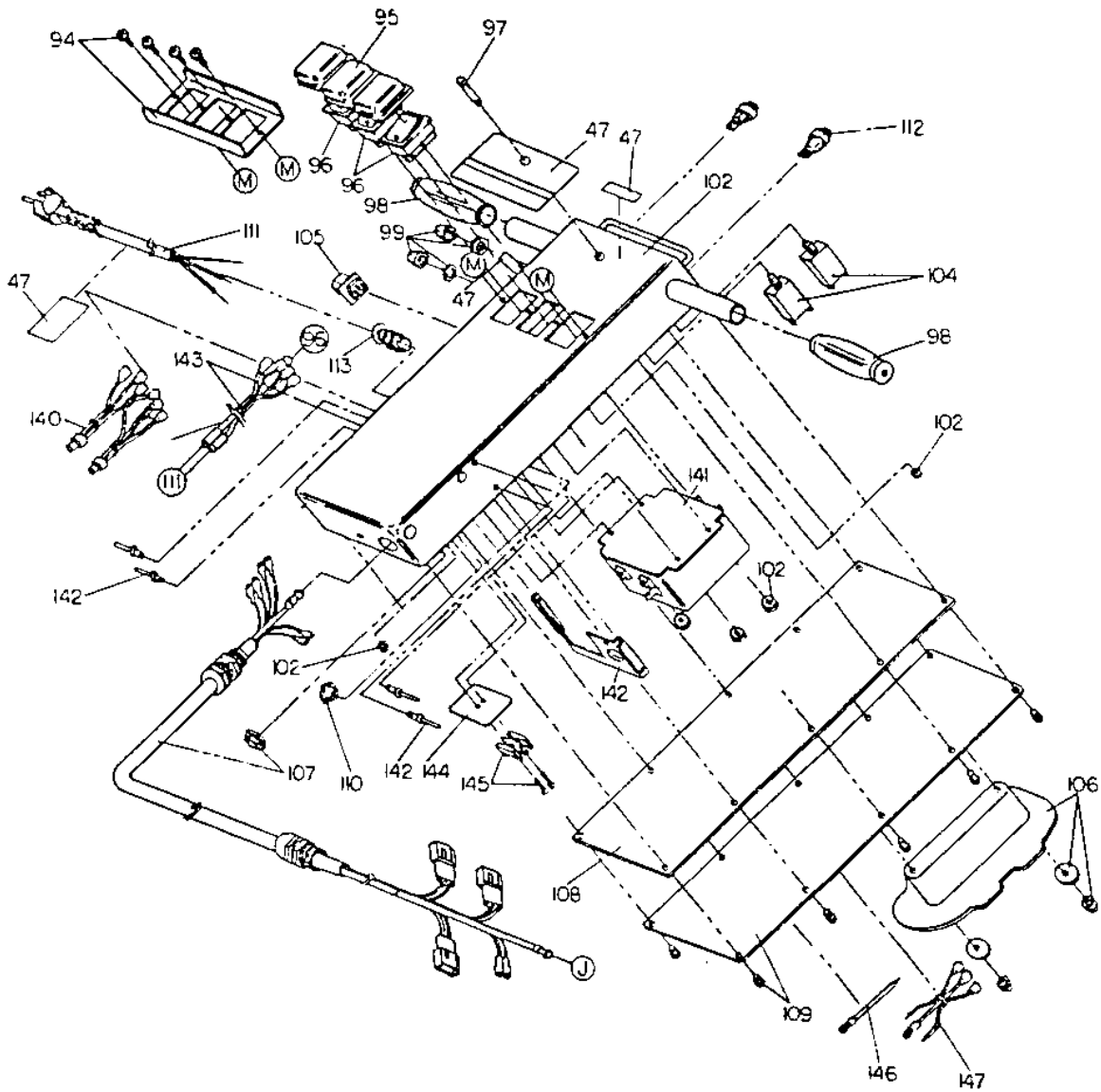

**POLARIS 800 & 1200  
HANDLE ASSEMBLY**

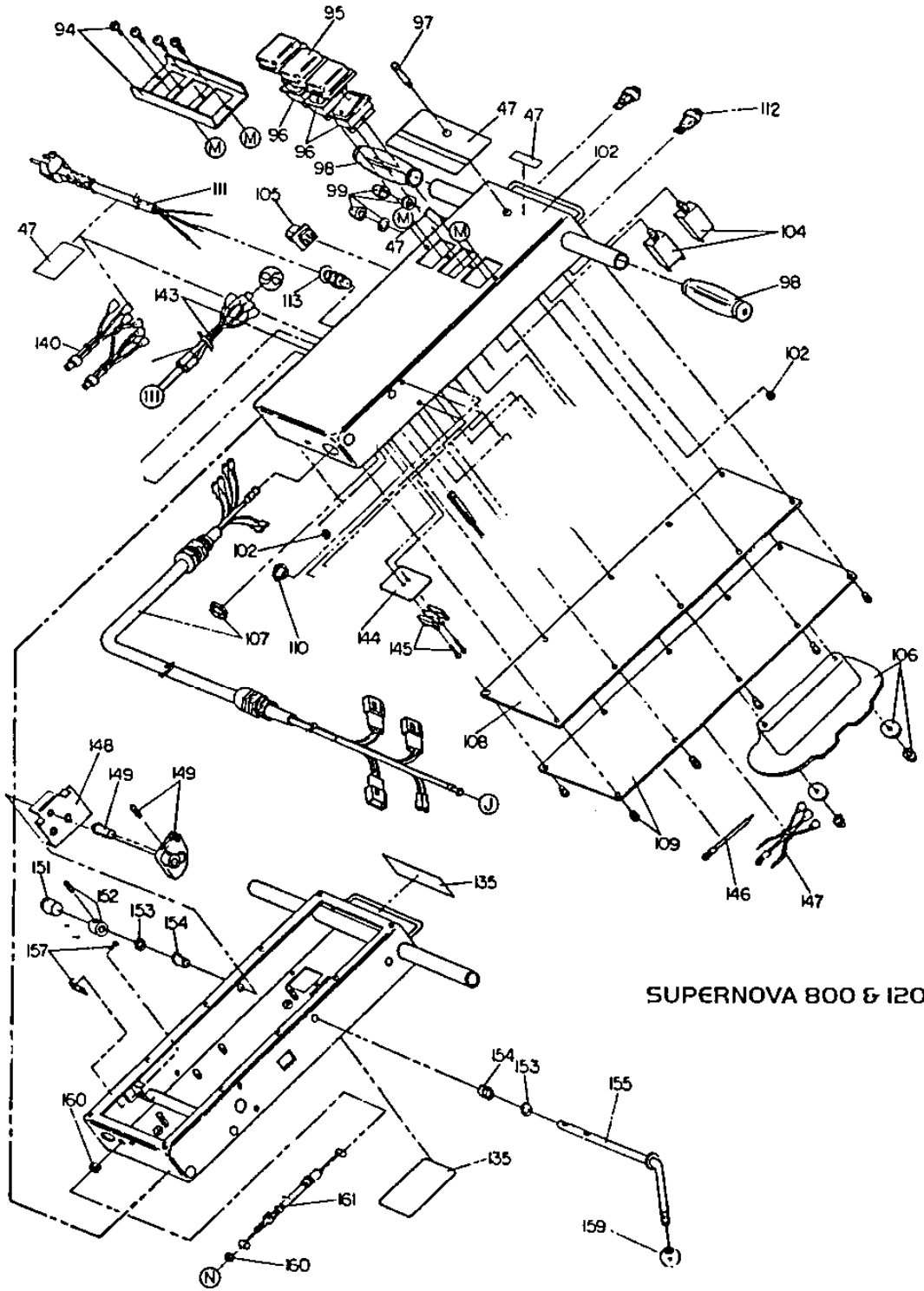

SUPERNOVA 800 & 1200

ADDITIONAL PARTS FOR SUPERNOVA

**SUPERNOVA 800 & 1200  
HANDLE ASSEMBLY**

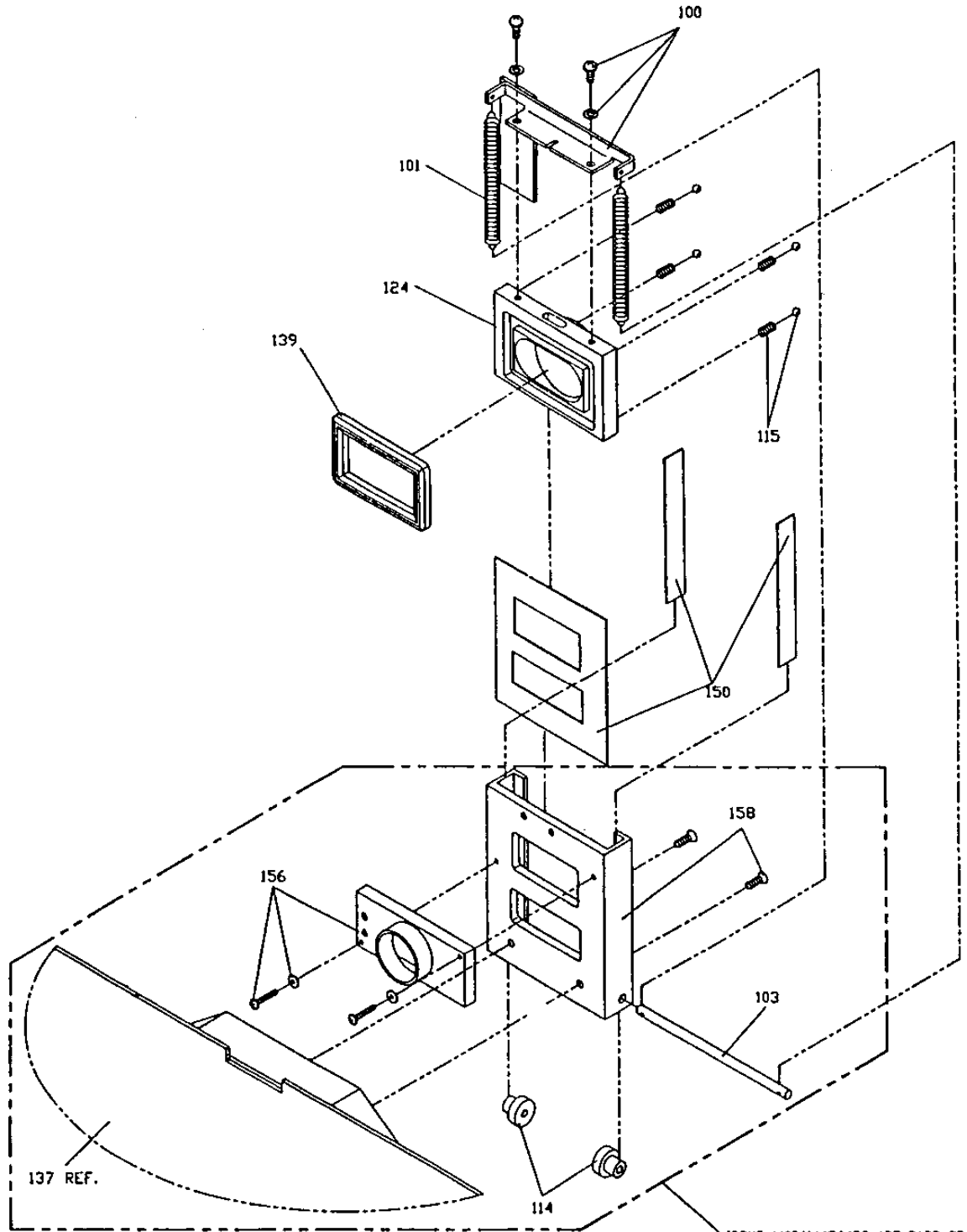

ITEMS #103,114,156,158 ARE PART OF  
FLOATING HEAD REAR ASSEMBLY,  
ITEM #137 (SEE FIG.3).

**SUPERNOVA 800 & 1200  
VACUUM VALVE ASSEMBLY**

**SUPERNOVA  
800 & 1200**

## POLARIS 800 & 1200 PARTS LIST

REF.	STOCK CODE	PART NO.	DESCRIPTION	QTY
1		D02391	CLIP, ADAPTER RETAINER STEEL	1
2	E02359	D02359	HOSE ADAPTER, ALUMINIUM	1
3	E02341	E02431	SEAL, VACUUM INTAKE, NEOPRENE	1
4		D02373	SHAFT, LID PIVOT 4 7/16" x 5/16"	2
5	E02372	D02372	SPRING DOME PIVOT & SLIDE BLOCK	5
6	E00491-1	80491A	DOME (VACUUM LID) ASSEMBLY	1
7	E02428	E02428	GASKET, VACUUM LID NEOPRENE 1/2" THICK	1
8	E82474A	82474A	FILTER SCREEN ASSEMBLY, VACUUM LID	1
9	E00618	J00618	HOSE, VACUUM, 2" ID X 6FT (POLARIS 800)	1
	E00618	J00618	HOSE, VACUUM, 2" ID X 7FT (POLARIS 1200)	1
10		L00795	PLUG, SOLUTION TANK	1
11	E02465-2	F02465-2	RECOVERY PAIL, POLARIS 800	2
	E02465-3	F02465-3	RECOVERY PAIL, POLARIS 1200	2
12		A00165	DRAIN NOZZLE, 1/2" BARB X 1/2" BARB	1
13		80263-3A	CLIP ASSEMBLY, DRAIN HOSE	2
14		J00598	DRAIN HOSE, 5/8" OD X 1/8" X 13" (POLARIS 800)	1
		J00598	DRAIN HOSE, 5/8" OD X 1/8" X 24" (POLARIS 1200)	1
15	E00138	A00138	90 ELBOW 1/2" MP X 3/8" BARB	1
16	E00099	A00099	90 ELBOW 1/2" MP X 5/8" BARB	2
17		J00637	HOSE CLAMP 5/8"	1
18		J00652	HOSE CLAMP 7/8"	1
19	E00613	J00595	SOLUTION HOSE 3/8" X 15"	1
20		82570A	LABEL KIT	1
21	E00575	H00575	DECAL KIT, POLARIS 800	1
	E00576	H00576	DECAL KIT, POLARIS 1200	1
22		F02463-7	SOLUTION TANK ASSEMBLY, POLARIS 800	1
		F02463-3	SOLUTION TANK ASSEMBLY, POLARIS 1200	1
22	E90008	F90008	FILTER WITH FRAME	1
23		82310A	SOLUTION TANK MOUNTING KIT	1
24		F02470-1	HOUSING, MOTOR, PLASTIC	1
25	E02488	F02488	COVER, BRUSH CHAMBER	1
26	E02538-1	82538-1A	BRUSH DRIVE MOTOR ASSEMBLY 220-240V	1
27		00185-6A	WIRE ASSEMBLY GROUND	1
28	E00398-1	D00398-1	PULLEY, BRUSH DRIVE MOTOR	1
29	E00779-1	L00779-1	BELT, TIMING	1
30		82378A	COVER PLATE ASSEMBLY, SPRING	1
31		82362A	BRUSH CHAMBER ASSEMBLY	1
32	E00144	A00144	90 ELBOW 1/8" FP X 1/4"C	2
33	E02366	D02366	GLIDE, BACK SS	1
34	E02365	D02365	GLIDE, FRONT SS	1
35	E80500A	80500A	SLIDE BLOCK ASSEMBLY (INCL SPRINGS & PTFE SLIDES)	2
36	E00504	F00504	WASHER, SLIDE BLOCK 1/16" x 25/64" x 2"	1
37	E82235A	82235A	STRING GUARD ASSEMBLY	1
38	E00536B	G00536	BEARING, BRUSH	2
39	E00505	F00505	BRUSH	1
40	E02371	D02371	SHAFT, BRUSH 1/2" X 18"	1
41	E82376A	82376A	SLINGER ASSEMBLY, ROTARY BRUSH	1
42	E00398-2	D00398-2	PULLEY, ROTARY BRUSH	1
43	E02298	C02298	WASHER, 3/32" X 7/16" X 5/8" (14")	4
44	E00091-2	A00091-2	SPRAY TIP BRASS 1/8" NPT 110 03	2
45	E82368A	82368A	COVER PLATE ASSEMBLY, OPEN END	1
46		82367A	COVER PLATE ASSEMBLY, PULLEY END	1
48		D02344-1	PIVOT EXTENSION LID FRAME (800)	2
		D02344	PIVOT EXTENSION LID FRAME (1200)	2
49		82361A	BRACKET ASSEMBLY, HOSE GUIDE	1
50		82383A	PIN ASSEMBLY, RETAINING	1
51		80187A	CLAMP ASSEMBLY, CORD	1
52	E00712-4	K00712-4	CAP, END	4
53		E02450	GASKET, COOLING AIR DUCT	2
54	E00654	J00654	HOSE, EXHAUST	1
55		D02343	DUCT, COOLING AIR	1
56		D02342-1	FRAME UPPER	1
58	E02514	82514A	WHEEL ASSEMBLY	4
	E02305	C02305	CAP, PUSH-ON 1/2"	4
59		K00674	BUSHING NYLON 1/2"	2

REF.	STOCK CODE	PART NO.	DESCRIPTION	QTY
60	AD00418	D00418-14	AXLE, WHEEL	1
61	E00790	80790A	MUFFLER KIT	1
63		82291A	VACUUM MOTOR MOUNTING ASSEMBLY	1
64		F00463	LOOM, CORRUGATED	1
65	LA4503P	117148-13	VACUUM MOTOR, 2 STAGE 220-240V REVERSE FAN	2
66		K00725	CAP, LATCH HANDLE (EARLY MODEL)	1
67		82355A	LATCH HANDLE ASSEMBLY (EARLY MODEL)	1
68		C02310	CAP SCREW, HEX HEAD ¼"-20 X 1 ¼" (EARLY MODEL)	1
69		82357A	LATCH HANDLE SPRING ASSEMBLY (EARLY MODEL)	1
70	E00143	A00143	TEE, MALE BRANCH, BRASS 1/8"MP X ¼"C TUBE FITTING	1
71	E00132	A00132	90 ELBOW 1/8"MP X ¼"C	1
72	E02532-1	G02537	SOLENOID, 1/8"NPT 220-240V	1
73	E00135	A00135	TEE, STREET 1/8"NPT	1
74	E00055	A00055	NIPPLE, SHORT 1/8"NPT	1
75	PC800118	11-800118	BUSHING, REDUCER, 3/8" X ½" NPT	1
76	E00133	A00133	90 ELBOW 3/8"MP X ¼"C	1
77	E00145	A00145	TUBE FITTING ¼"FP X ¼"C	1
78	E00124	A00124	NUT, HEX ¼" PIPE	2
79		B02214	NUT, PIPE, PLASTIC	2
80		80418-6A	SHAFT ASSEMBLY, HANDLE	1
81	E00085-13	A00085-5	TUBE, COPPER ¼" OD, LEFT SPRAY TIPS	1
82	E00085-14	A00085-4	TUBE, COPPER ¼" OD, RIGHT SPRAY TIPS	1
83		A00085-7	TUBE, COPPER ¼" OD X 25 7/8"	1
84		A00085-6	TUBE, COPPER ¼" OD X 16 9/16"	1
85	E00240	C00240	SPACER, 3/16" X ½" X 1" OD	5
86	E02448	E02448	GASKET, VACUUM MOTOR	1
87		D02370	BRACKET, BRUSH DRIVE MOTOR	1
88	E10763-1 FJ4401B	8090-951-250 S2100818A	SHURFLO PUMP 230V FLOJET PUMP 230V	1 1
89		02341A	LOWER FRAME ASSEMBLY	1
90	E00061	A00061	ADAPTER, 3/8" BARB X ¼" FP	1
91	E00052	A00052	90 ELBOW, ¼"FP X ¼"MP	2
92	E00709	K00709	FILTER STRAINER, IN-LINE	1
	E00709-1	K00709-1	SCREEN, IN-LINE STRAINER	1
	E00709-2	K00709-2	CAP, IN-LINE STRAINER	1
	E00709-3	K00709-3	GASKET (SEAL) IN-LINE STRAINER	1
93	GU00104	A00104	QUICK DISCONNECT ¼"FP MALE	1
94		82414A	SWITCH GUARD ASSEMBLY	1
95	E00214-2	B00214-2	COVER, ROCKER SWITCH	3
96	E02211-1	B02211-1	ROCKER SWITCH, ILLUMINATED	3
97	E02196	B02196	LIGHT, INDICATOR, GREEN LENS	1
98	A100715	K00715B-1	GRIP HANDLE, BLACK	2
99	E02193	B02193	BOOT, FLEX, CIRCUIT BREAKER	2
102		D02403	HANDLE, ADJUSTABLE	1
104	E02191	B02191	CIRCUIT BREAKER, 1.5A	1
105		80188A	OUTLET ASSEMBLY, ACCESSORY (NOT FITTED)	1
106		82408A	CORD WRAP ASSEMBLY	1
107	E00185-32A	00185-33A	CORD ASSEMBLY, HANDLE TO LOWER FRAME	1
108		E03432	GASKET, HANDLE	1
109		82409A	COVER PLATE ASSEMBLY	1
110		B02214	LOCK NUT	1
111	BE4901	B00225	POWER CORD EC 220-240V 1.5MM	1
112	E02187	B02187	TOGGLE SWITCH (EARLIER VERSION)	1
	RS4902	233-3936	TOGGLE SWITCH COVER (EARLIER VERSION)	1
	E02173	B02173	SWITCH, PUSH BUTTON (LATER VERSION)	1
113	E11199	B11199	STRAIN RELIEF, POWER CORD	1
			CORD ANCHOR (NOT SHOWN)	1
116	E02229	B02229	RECTIFIER	1
	RS5218	395-4427	RECTIFIER (ALTERNATIVE)	1
120		00185-37A	HARNES, RECTIFIER 220-240V	1
121		82171A	RECTIFIER, FISH PAPER ASSEMBLY	1
166	E02322	C02322	SCREW, MACHINE HEX HEAD, ¼"-20 X 1 ¼"	2
	JE00233	C00233	WASHER, FLAT ¼"	2
	JE00254	C00254	WASHER, SPRING ¼"	2
176	E00140	A00140	90 ELBOW ¼" MP X ¼" C	1
	E90001A	B90001	FILTER EMI - RFI 250V	1

# SUPERNOVA 800 & 1200 PARTS LIST

REF.	STOCK CODE	PART NO.	DESCRIPTION	QTY
1		D02391	CLIP, ADAPTER RETAINER STEEL	1
2	E02359	D02359	HOSE ADAPTER, ALUMINIUM	1
3	E02341	E02431	SEAL, VACUUM INTAKE, NEOPRENE	1
4		D02373	SHAFT, LID PIVOT 4 7/16" X 5/16"	2
5	E02372	D02372	SPRING DOME PIVOT	1
		D03375	SPRING, SLIDE BLOCK	4
6	E00491-1	80491A	DOME (VACUUM LID) ASSEMBLY	1
7	E02428	E02428	GASKET, VACUUM LID NEOPRENE 1/2" THICK	1
8		82474A	FILTER SCREEN ASSEMBLY, VACUUM LID	1
9	E00618	J00618	HOSE, VACUUM, 2" ID X 6FT (POLARIS 800)	1
	E00618	J00618	HOSE, VACUUM, 2" ID X 7FT (POLARIS 1200)	1
10		L00795	PLUG, SOLUTION TANK	1
11		F11815-2	RECOVERY PAIL, SUPERNOVA 800	2
		F11816	RECOVERY PAIL, SUPERNOVA 1200	2
12		A00165	DRAIN NOZZLE, 1/2" BARB X 1/2" BARB	1
13		80263-3A	CLIP ASSEMBLY, DRAIN HOSE	2
14		J00598	DRAIN HOSE, 5/8" OD X 1/8" X 13" (POLARIS 800)	1
		J00598	DRAIN HOSE, 5/8" OD X 1/8" X 24" (POLARIS 1200)	1
15	E00138	A00138	90 ELBOW 1/2" MP X 3/8" BARB	1
16	E00099	A00099	90 ELBOW 1/2" MP X 5/8" BARB	2
17		J00637	HOSE CLAMP 5/8"	1
18		J00652	HOSE CLAMP 7/8"	1
19	E00613	J00595	SOLUTION HOSE 3/8" X 15"	1
20		82570A	LABEL KIT	1
21	E00575	H00575	DECAL KIT, POLARIS SUPERNOVA 800	1
	E00576	H00576	DECAL KIT, POLARIS SUPERNOVA 1200	1
22		F11809	SOLUTION TANK ASSEMBLY, SUPERNOVA 800	1
		F11820-1	SOLUTION TANK ASSEMBLY, SUPERNOVA 1200	1
22	E90008	F90008	FILTER WITH FRAME	1
23		82310A	SOLUTION TANK MOUNTING KIT	1
24		F11819	HOUSING, MOTOR, PLASTIC	1
25	E02488	F11820-1	COVER, BRUSH CHAMBER	1
26	E02538-1	82523A	BRUSH DRIVE MOTOR ASSEMBLY 220-240V	1
27		00185-6A	WIRE ASSEMBLY GROUND	1
28	E00398-6	D00398-6	PULLEY, BRUSH DRIVE MOTOR	1
29	E00779-160	L00779	DRIVE BELT, SUPERNOVA (160XL)	1
30		83355A	COVER PLATE ASSEMBLY, SPRING	1
31		D010154	BRUSH CHAMBER ASSEMBLY	1
32	E00144	A00144	90 ELBOW 1/8" FP X 1/4"C	2
33	E03360	D03360	GLIDE, BACK SS	2
34	E03358	D03358	GLIDE, FRONT SS	2
	E810083A	810083A	TEFLON GLIDE SET (NOT SHOWN)	1
35	E80500A	80500A	SLIDE BLOCK ASSEMBLY (INCL SPRINGS & PTFE SLIDES)	2
36	E00504	F00504	WASHER, SLIDE BLOCK 1/16" x 25/64" x 2"	1
37	E82235A	82235A	STRING GUARD ASSEMBLY	1
38	E00536B	G00536	BEARING, BRUSH	2
39		F02477	BRUSH	1
40	E02371	D02371	SHAFT, BRUSH 1/2" X 18"	1
41	E82376A	82376A	SLINGER ASSEMBLY, ROTARY BRUSH	1
42	E00398-2	D00398-2	PULLEY, ROTARY BRUSH	1
43	E02298	C02298	WASHER, 3/32" X 7/16" X 5/8" (14")	4
44	E00089	A00089	SPRAY TIP BRASS 1/8" NPT 110 02	4
45	E83352A	83352A	COVER PLATE ASSEMBLY, OPEN END	1
46	E83353A	83353A	COVER PLATE ASSEMBLY, PULLEY END	1
48		D02344-1	PIVOT EXTENSION LID FRAME (800)	2
		D02344	PIVOT EXTENSION LID FRAME (1200)	2
49		82361A	BRACKET ASSEMBLY, HOSE GUIDE	1
50		82383A	PIN ASSEMBLY, RETAINING	1
51		80187A	CLAMP ASSEMBLY, CORD	1
52	E00712-4	K00712-4	CAP, END	4
53		E02450	GASKET, COOLING AIR DUCT	2
54	E00654	J00654	HOSE, EXHAUST	1
55		D02343	DUCT, COOLING AIR	1
56		D02342-1	FRAME UPPER	1
57		K00705	FOOT, RUBBER	2

REF.	STOCK CODE	PART NO.	DESCRIPTION	QTY
58	E02514	82514A	WHEEL ASSEMBLY	4
	E02305	C02305	CAP, PUSH-ON ½"	4
59		K00674	BUSHING NYLON ½"	2
60	AD00418	D00418-14	AXLE, WHEEL	1
61	E00790	80790A	MUFFLER KIT	1
63		82291A	VACUUM MOTOR MOUNTING ASSEMBLY	1
64		F00463	LOOM, CORRUGATED	1
65	LA4503P	117148-13	VACUUM MOTOR, 2 STAGE 220-240V REVERSE FAN	2
66		K00725	CAP, LATCH HANDLE	1
67		82355A	LATCH HANDLE ASSEMBLY	1
68		C02310	CAP SCREW, MACHINE STEEL HEX HEAD ¼"-20 X 1 ¼"	1
69		82357A	LATCH HANDLE SPRING ASSEMBLY	1
70	E00153	A00153	TEE, MALE RUN, BRASS 1/8"MP X ¼"C TUBE FITTING	1
71	E00132	A00132	90 ELBOW 1/8"MP X ¼"C	1
72	E02532-1	G02537	SOLENOID, 1/8"NPT 220-240V	1
73	E00152	A00152	BRANCH TEE, MALE 1/8"NPT	1
74	E00055	A00055	NIPPLE, SHORT 1/8"NPT	1
75	PC800111	11-800111	BUSHING, REDUCER, 3/8" X ½" NPT	1
76	E00133	A00133	90 ELBOW 3/8"MP X ¼"C	1
77	E00145	A00145	TUBE FITTING ¼"FP X ¼"C	1
78	E00124	A00124	NUT, HEX ¼" PIPE	2
79		B02214	NUT, PIPE, PLASTIC	2
80		80418-6A	SHAFT ASSEMBLY, HANDLE	1
81	E00085-13	A00085-13	TUBE, COPPER ¼" OD, LEFT SPRAY TIPS	1
82	E00085-14	A00085-14	TUBE, COPPER ¼" OD, RIGHT SPRAY TIPS	1
83		A00085-16	TUBE, COPPER ¼" OD X 25 7/8"	1
84		A00085-6	TUBE, COPPER ¼" OD X 16 9/16"	1
85	E00240	C00240	SPACER, 3/16" X ½" X 1" OD	5
86	E02448	E02448	GASKET, VACUUM MOTOR	1
87		D03365	BRACKET, BRUSH DRIVE MOTOR	1
88	E10763-1	8090-951-250	SHURFLO PUMP 230V	1
	FJ4401B	S2100818A	FLOJET PUMP 230V	1
89		03370A	LOWER FRAME ASSEMBLY	1
90	E00061	A00061	ADAPTER, 3/8" BARB X ¼" FP	1
91	E00052	A00052	90 ELBOW, ¼"FP X ¼"MP	2
92	E00709	K00709	FILTER STRAINER, IN-LINE	1
	E00709-1	K00709-1	SCREEN, IN-LINE STRAINER	1
	E00709-3	K00709-3	GASKET (SEAL) IN-LINE STRAINER	1
	E00709-2	K00709-2	CAP, IN-LINE STRAINER	1
93	GU00104	A00104	QUICK DISCONNECT ¼"FP MALE	1
94		82414A	SWITCH GUARD ASSEMBLY	1
95	E00214-2	B00214-2	COVER, ROCKER SWITCH	3
96	E02211-1	B02211-1	ROCKER SWITCH, ILLUMINATED	3
97	E02196	B02196	LIGHT, INDICATOR, GREEN LENS	1
98	A100715	K00715B-1	GRIP HANDLE, BLACK	2
99	E02193	B02193	BOOT, FLEX, CIRCUIT BREAKER	2
100		83349A	SPRING BRACKET, VACUUM VALVE ASSEMBLY	1
101		010666A	SPRING, VACUUM VALVE SLIDE RETURN KIT	1
102		D02338-2	HANDLE, ADJUSTABLE	1
103		D03356	SHAFT, VACUUM VALVE	1
104	E02191	B02191	CIRCUIT BREAKER, 1.5A	1
105		80188A	OUTLET ASSEMBLY, ACCESSORY (NOT FITTED)	1
106		82408A	CORD WRAP ASSEMBLY	1
107	E00185-32A	00185-33A	CORD ASSEMBLY, HANDLE TO LOWER FRAME	1
108		E03432	GASKET, HANDLE	1
109		82409A	COVER PLATE ASSEMBLY	1
110		B02214	LOCK NUT	1
111	BE4901	B00225	POWER CORD EC 220-240V 1.5MM	1
112	E02173	B02173	SWITCH, PUSH BUTTON	2
113	E11199	B11199	STRAIN RELIEF, POWER CORD	1
			CORD ANCHOR (NOT SHOWN)	1
114		E03435	BUMPER, VACUUM VALVE	2
115		D03372	SPRING AND BALLS KIT	4
		D03373		4
116		C00300-46	MANDREL BLIND RIVET ⅜ X ¼	10
117		C00304	WASHER STEEL ⅜ X ⅜	10
118		F11820-2	COVER	1
119		B02175	EMC / RFI FILTER ASSEMBLY 240V	1
120		00185-31A	HARNESS, RECTIFIER 220-240V	1

REF.	STOCK CODE	PART NO.	DESCRIPTION	QTY
121		82202A	RECTIFIER, FISH PAPER ASSEMBLY	1
122	E00657	J00657	CLAMP, 2 1/8 x 2 3/8	2
123	E00621	J00621	HOSE, AIR VALVE ASSEMBLY 5"	1
124		803364A	SLIDE, VACUUM VALVE ASSEMBLY	1
125		83348A	BRACKET, FRONT, PULL CABLE ASSEMBLY	1
126		82172A	SWITCH BRACKET ASSEMBLY	1
127	E02172	B02172	SWITCH, MOTOR REVERSE	3
128		A00085-15	TUBE, TIP CONNECTOR	2
129		A00156	BRANCH TEE, FEMALE	2
130		83374A	FLOATING HEAD RETAINING PIN ASSEMBLY	1
131		80465A	GLIDE, SIDE	2
132		83361A	ADAPTER, FRONT HEAD	1
133	E00618-1	J00618-1	HOSE, FRONT HEAD ASSEMBLY, 1 1/2"	1
134		J00656	CLAMP 1 1/4 X 1 7/16"	2
136	E03366	D03366	FLOATING HEAD, FRONT	1
137	E03367	D03367	FLOATING HEAD, REAR ASSEMBLY	1
138	E00464	F00464	BUTTON, GLIDE	8
139	E03434	E03434	SEAL, SLIDE BLOCK	1
140		E00185-38A	WIRE CONNECTOR ASSEMBLY, HANDLE, JUMPER	1
144		B02195	INSULATOR, TERMINAL BLOCK 250V (TUV)	1
145		B02190	TERMINAL BLOCK 250V	1
146		00185-39A	HARNESS, TERMINAL BLOCK TO EARTH POINT	1
147		00185-36A	HARNESS, TERMINAL BLOCK TO RFI FILTER	1
148	E03350	D03350	STOP BRACKET	1
149	E83346A	83346A	CAM WITH PLUNGER, PULL CABLE	1
150	E80459A	80459A	GASKET, VACUUM VALVE GUIDE	1
151		K02716	CAP, PROTECTIVE	1
152		C02277	COLLAR, SHAFT, 3/8 ID	1
		C02257	SET SCREW	
153		C02287	WASHER, TEFLON 3/8 ID	2
154		K00678	BUSHING NYLINER 3/8 ID	2
155	E03347	D03347	LEVER ARM	1
156		D03363	ADAPTER PLATE, VALVE GUIDE (ORDER WITH D03376)	1
157		83357A	CLIP, PULL CABLE ASSEMBLY	1
158		D03345	GUIDE, VACUUM VALVE ASSEMBLY	1
159		K02712	KNOB, BALL	1
160	E00449	E00449	GROMMET	2
161		D03369	CABLE	1
162		00185-42A	HARNESS, SWITCHES	1
163	E02229	B02229	RECTIFIER	1
	RS5218	395-4427	RECTIFIER (ALTERNATIVE)	1
166	E02322	C02322	SCREW, MACHINE HEX HEAD, 1/4"-20 X 1 3/4"	2
	JE00233	C00233	WASHER, FLAT 1/4"	2
	JE00254	C00254	WASHER, SPRING 1/4"	2
176	E00140	A00140	90 ELBOW 1/4" MP X 1/4" C	2

# PUMP PARTS LIST

## SHURFLO PUMP 8000 SERIES, BY-PASS

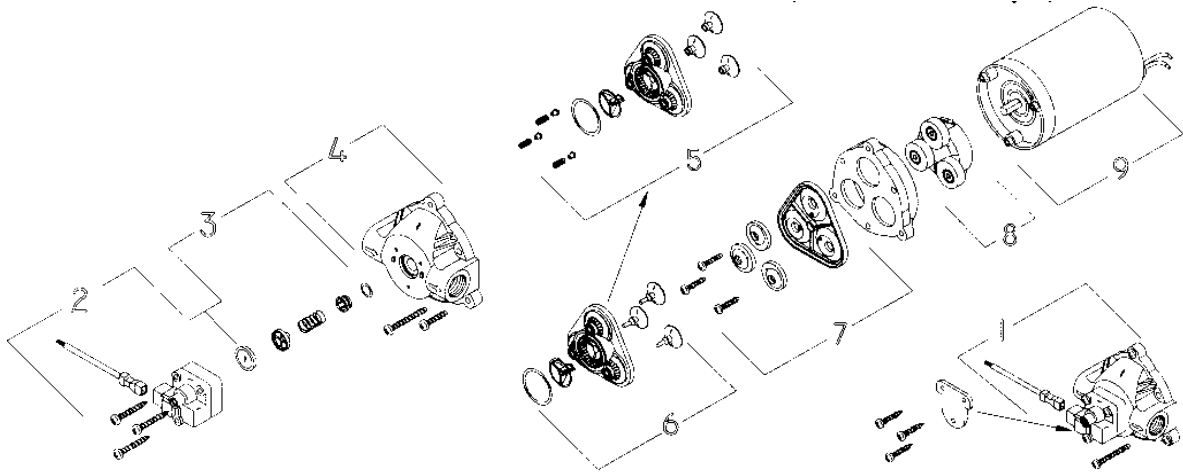

REF.	STOCK CODE	PART NO.	DESCRIPTION	QTY
1			COMPLETE HEAD ASSEMBLY, BY-PASS	1
2			PRESSURE SWITCH ASSEMBLY ( NOT FITTED)	
3			CHECK VALVE COMPONENTS (NOT AVAILABLE)	1
4	SH5205	94-379-01	UPPER HOUSING	1
5	PC809337	94-391-26	BY-PASS VALVE AND DISCHARGE VALVE ASSEMBLY	1
6			VALVE PLATE ASSEMBLY (NOT AVAILABLE)	1
7	SH5203	94-385-30	DIAPHRAGM, PISTON COMPONENTS & DRIVE ASSEMBLY	1
8			DRIVE ASSEMBLY (SEE 7)	1
9			MOTOR ASSEMBLY (LESS BASE PLATE)	1

# HAND TOOL PARTS LIST

## AC1021

### AC1021 Glidemaster Hand Tool



### AC1021 Glidemaster Hand Tool - Spare Parts

E00832-A Lever



E00526 K-valve, single lug



E00053 Elbow  
45 deg, 1/4



E00095-1  
Bush  
1/8Fx1/4M



E00095  
Flood  
Jet

GU00102  
Solution  
Connector,  
Female



CH00111 Nipple



E00835  
Spring



E00833  
Cap nut



KP4002  
'O' - ring



E00836  
Stem



RS5207 Screw M5  
RS5208 Nut, Nyloc

# WIRING DIAGRAMS

POLARIS MODEL 500 & 700

115V AND 230V AC 50/60 HZ  
WIRING DIAGRAM

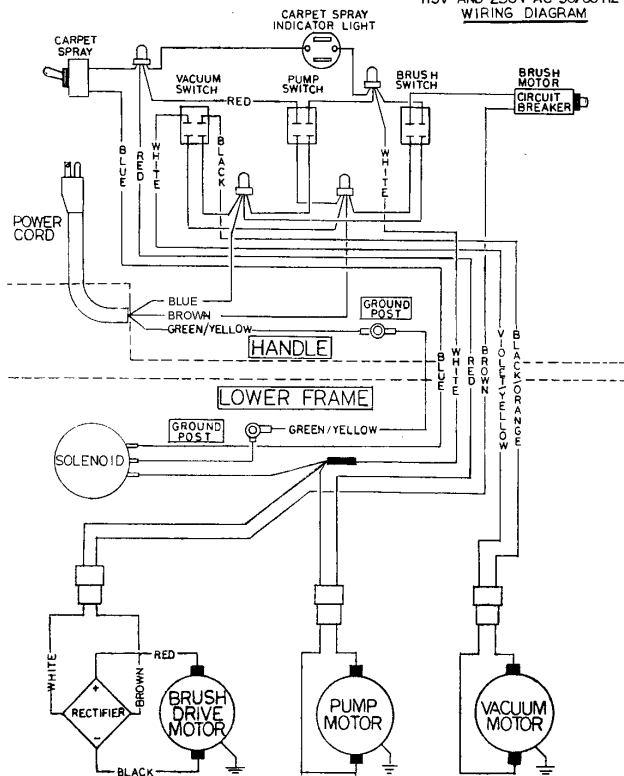

POLARIS MODEL 800 AND 1200

230 V AC, 50/60 HZ  
WIRING DIAGRAM, ND10198

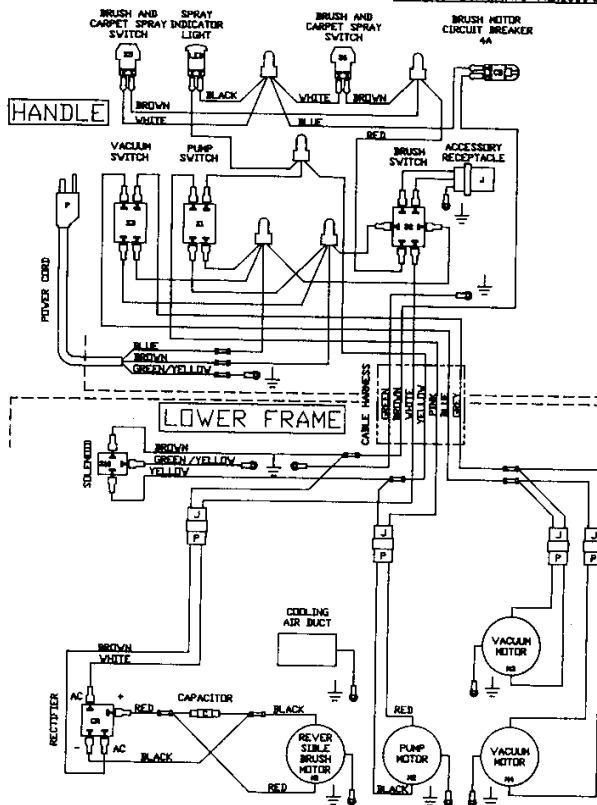

SUPERNOVA  
MODEL 800 AND 1200

230 V AC, 50/60 HZ  
WIRING DIAGRAM, NO.10197

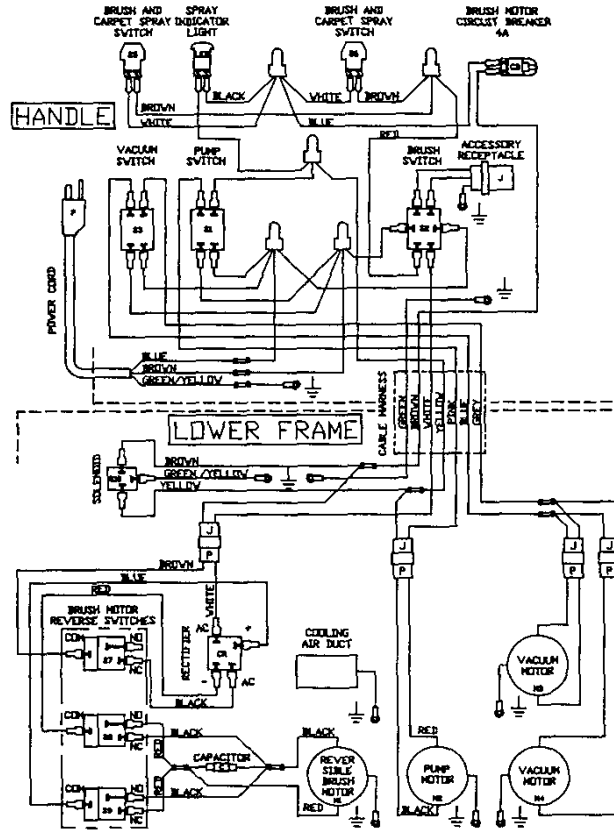

SUPERNOVA MODEL  
800 AND 1200, TV MODELS

230 V AC, 50/60 HZ  
WIRING DIAGRAM, NO.10123

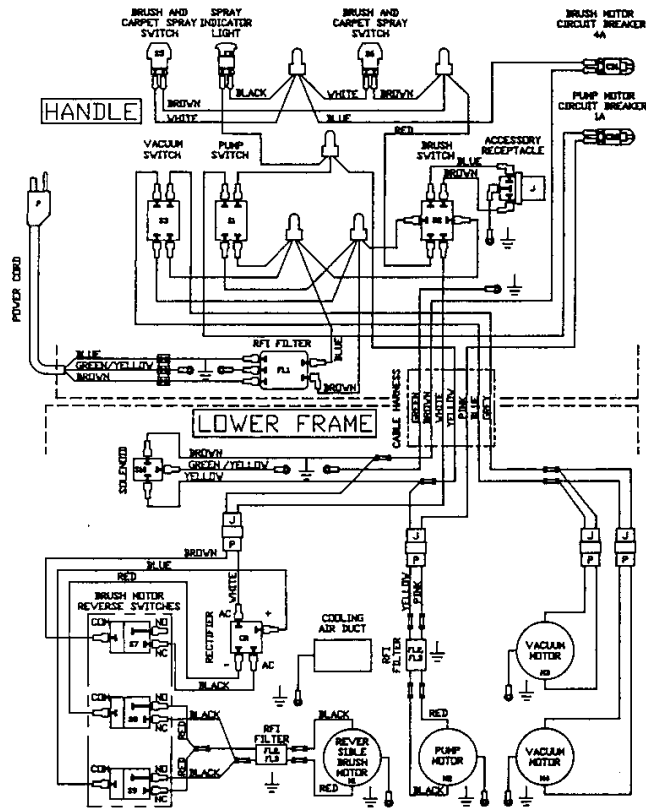

# DECLARATION OF CONFORMITY

We:  
Prochem Europe Ltd.,  
Oakcroft Road,  
Chessington,  
Surrey, KT9 1RH  
UK  
(Importer / EC Responsible Person)

E.D.I.C  
1753, Blake Avenue,  
Los Angeles,  
California, 90031-1006  
USA  
(Manufacturer)

Declare that the product(s):

Type(s): **POLARIS / SUPERNOVA**  
Model(s): **SP500 / SP700 / SP800 / SP1200 / SN700 / SN800 / SN1200**  
Description: **CARPET / FLOOR CLEANING MACHINES 220 - 240V 50Hz**

Have been manufactured in conformity with the following standards and specifications:

**EN 60335-1:1995**  
**EN 60335-2-68:1999**  
**EN61000-3-2:2000**  
**EN61000-3-3:1995**

And comply with the requirements of (as amended):

**73/23/EEC**      **Low Voltage (LVD) Directive (93/68/EEC)**  
**89/336/EEC**    **Electromagnetic Compatibility (EMC) Directive (92/31/EEC) (93/68/EEC)**

A Technical file is held by Prochem Europe Ltd.

Certificate of compliance and test reports have been issued by:

SGS United Kingdom Ltd.  
Unit 10, Bowburn South Industrial Estate  
Bowburn, Durham DH6 5AD  
Ref: DUR40718/2/R/SW/03  
DUR41117/2/R/PB/03  
DUR41118/2/A/SW/03  
DUR40718/1/EMC/CL/03  
DUR41117/01/EMC/CL/03  
DUR41118/01/EMC/CL/03

Signed  
(For and on behalf of the Importer / EC Responsible Person)

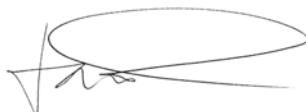

Name: J Hattersley  
Position: Equipment Product Manager  
Place of Issue: Chessington UK  
Date of Issue: 14/3/2011